



STALMOT' smart ideas

2025



Tworzenie nowoczesnych rozwiązań meblowych to nasza pasja, którą pielęgnujemy od ponad 30 lat. Współpracując z najlepszymi fabrykami mebli zdobyliśmy know-how i cenne doświadczenie w branży meblarskiej. Dzięki temu nasze produkty wyróżniają się na rynku wzornictwem, funkcjonalnością i niezawodnością, tworząc realną wartość dodaną dla naszych klientów.

Creating modern furniture solutions is our passion, which we have cultivated for more than 30 years. Working with the best furniture factories, we have gained know-how and valuable experience in the furniture industry. As a result, our products stand out in the market with their design, functionality and reliability, creating real added value for our customers.

PF 107-B-5

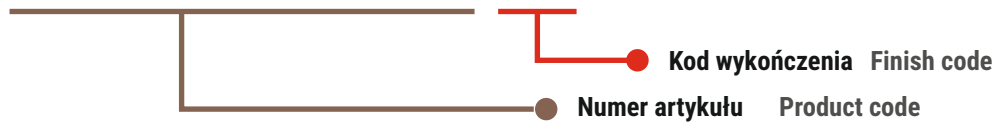

Typowe kody wykończeniowe

- 0 bez pokrycia
- 1 ocynk
- 4 kolor biały połysk - malowanie proszkowe
- 5 kolor czarny połysk - malowanie proszkowe
- 8 chrom połysk - galwanizacja
- 12 kolor czarny mat - malowanie proszkowe
- 13 szary antracyt - malowanie proszkowe
- 19 czarny mat struktura - malowanie proszkowe
- 20 aluminium polerowane
- 27 stal nierdzewna szczotkowana
- 28 stal nierdzewna polerowana
- 34 nikiel szczotkowany - galwanizacja
- 36 kolor aluminium półmat - malowanie proszkowe

Objaśnienia znaków w katalogu

MIN minimalne zamówienie

- w produkcji ciągłej
- ilość wyrobów na komplet

Standard finish option

- 0 no covering
- 1 zinc coating
- 4 white polished - powder coating
- 5 black polished - powder coating
- 8 chrome
- 12 black matt - powder coating
- 13 anthracite grey - powder coating
- 19 black structure - powder coating
- 20 aluminium polished
- 27 stainless steel brushed
- 28 stainless steel polished
- 34 brushed nickel - galvanization
- 36 aluminium colour semi-matt - powder coating

Explanatory signs in catalogue

MIN minimal order

- in continuous production
- quantity/set

SPIS TREŚCI

LIST OF CONTENT

3-23

Mechanizmy sofy i narożnika
Sofa and corner sofa mechanisms

24-27

Podnośniki do otoman
Lifting mechanisms for corner sofa storage

28-31

Ramy i podnośniki do łóżek
Frames and lifting mechanisms for beds

32-34

Mechanizmy siedziska
Seat mechanisms

35-36

Mechanizm podnóżka
Footrest mechanism

37-42

Mechanizmy oparcia
Backrest mechanisms

43-50

Mechanizmy podłokietnika i zagłówka
Armrest and headrest mechanisms

51-53

Mechanizmy stolika
Table mechanisms

54-64

Okucia drobne
Fittings

65-67

Akcesoria z tworzyw
Plastic accessories

68-70

Nogi meblowe
Furniture legs

71-77

Podstawy z obrotem
Swivel bases

PUMA™ SYSTEM

FUNKCJA RELAKSU I SPANIA DO NAROŻNIKA
RELAXATION AND SLEEPING FUNCTION FOR A CORNER SOFA

- ✔ Prosta konstrukcja mebla i łatwy montaż mechanizmu
Simple construction of the furniture and easy assembly of the mechanism
- ✔ Łatwa obsługa mebla przez użytkownika
User-friendly furniture operation
- ✔ Wygodne materace
Comfortable mattresses



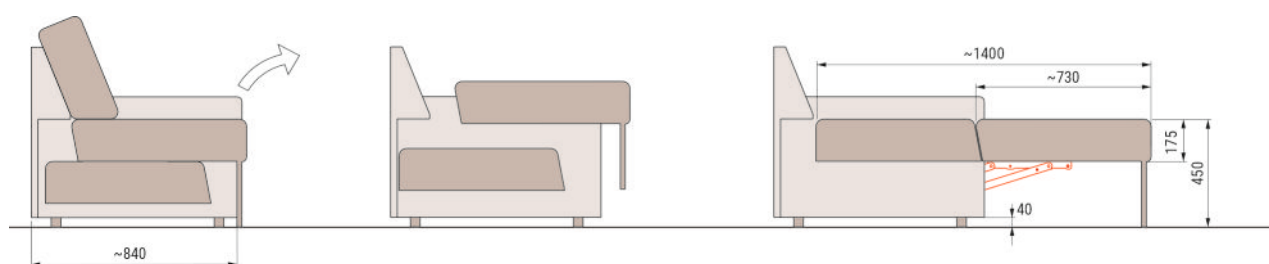

mechanizm PUMA

● **PF 107-B-5** MIN 10



INDUSTRIAL PROPERTY

AKCESORIA WYMAGANE REQUIRED ACCESSORIES

synchronizator
synchronizing bar

● **PF 290-A-5** L=1375 ÷ 1435 ■ 1 MIN 10

L - wew. szerokość skrzyni / internal box width
regulacja co 10 mm / adjustment every 10 mm



sprężyna
spring

● **AS 119-1** F_s=350N ■ 2 MIN 100

● **AS 135-1** F_s=530N ■ 2 MIN 100

● **AS 252-1** F_s=760N ■ 2 MIN 100



PUMA™ PLUS

FUNKCJA RELAKSU I SPANIA DO NAROŻNIKA
RELAXATION AND SLEEPING FUNCTION FOR A CORNER UNIT

- ✔ Prosta konstrukcja mebla ze stałym oparciem bez poduch
Simple furniture construction with a fixed backrest and no cushions
- ✔ Łatwa obsługa mebla przez użytkownika
User-friendly furniture operation
- ✔ Rozkładanie mebla do pozycji relaksu, a następnie do pozycji spania
Reclining the furniture into a relaxation position, then into a sleeping position
- ✔ Wygodne materace
Comfortable mattresses



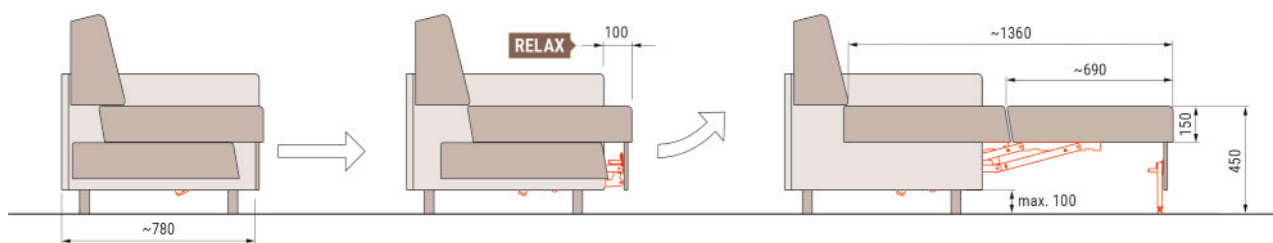

mechanizm PUMA PLUS

- **PF 190-Z-5** MIN 20



PATENT

AKCESORIA WYMAGANE REQUIRED ACCESSORIES

synchronizator
synchronizing bar

- **PF 290-A-5** L=1400 ÷ 1460 2 MIN 10

L - wew. szerokość skrzyni / internal box width
regulacja co 10 mm / adjustment every 10 mm



sprężyna przednia
front spring

- **AS 119-1** $F_s=340N$ 2 MIN 100
- **AS 135-1** $F_s=515N$ 2 MIN 100
- **AS 252-1** $F_s=735N$ 2 MIN 100



sprężyna tylna
rear spring

- **AS 189-1** $F_s=57N$ 2 MIN 100
- **AS 106-1** $F_s=145N$ 2 MIN 100



AKCESORIA DODATKOWE ADDITIONAL ACCESSORIES

noga automatyczna z regulacją wysokości
automatic leg with height adjustment

- **PF 280-H-5** 1 H=232 + MAX 38 MIN 5
- **PF 280-J-5** 1 H=202 + MAX 38 MIN 5



PUMA™ QS

FUNKCJA RELAKSU I SPANIA DO SOFY I NAROŻNIKA
RELAXATION AND SLEEPING FUNCTION FOR SOFA OR A CORNER SOFA

- ✓ Prosta konstrukcja mebla ze stałym oparciem
Simple furniture construction with a fixed backrest
- ✓ Łatwa obsługa mebla
User-friendly furniture operation
- ✓ Rozkładanie mebla do pozycji relaksu
Reclining the furniture to a relaxation position
- ✓ Rozkładanie mebla do pozycji spania o szerokości „Queen Size”
Unfolding the furniture into a "Queen Size" sleeping area
- ✓ Wygodne materace
Comfortable mattresses



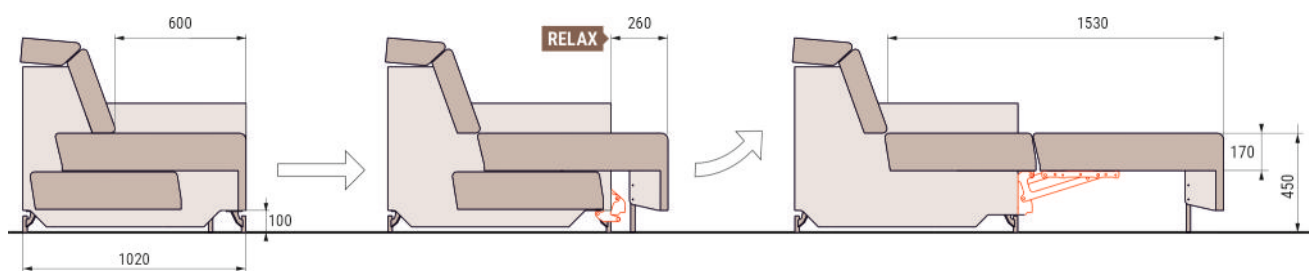

Mechanizm PUMA QS

PF 191-5 MIN 30

PATENT PENDING



AKCESORIA WYMAGANE REQUIRED ACCESSORIES

synchronizator
synchronizing bar

PF 290-W-5 L=2027 ÷ 2067 ■ 2 MIN 10

L - wew. szerokość skrzyni / internal box width
regulacja co 10 mm / adjustment every 10 mm



sprężyna
spring

● **AS 119-1** Fs=350N ■ 2 MIN 100

● **AS 135-1** Fs=530N ■ 2 MIN 100

● **AS 252-1** Fs=760N ■ 2 MIN 100



AKCESORIA DODATKOWE ADDITIONAL ACCESSORIES

noga podporowa
supporting leg

NG 320-5 H=228 ■ 2 MIN 30



PUMA™ PRO

FUNKCJA SPANIA DO SOFY
SOFA **BED FUNCTION**

- ✓ Prosta konstrukcja mebla
Simple furniture construction
- ✓ Łatwa obsługa mebla „jednym ruchem”
Easy one-motion operation of the furniture
- ✓ Duża powierzchnia spania
Large sleeping surface
- ✓ Wygodne materace
Comfortable mattresses
- ✓ Mebel może być dostarczany w paczkach
Furniture can be delivered in packages



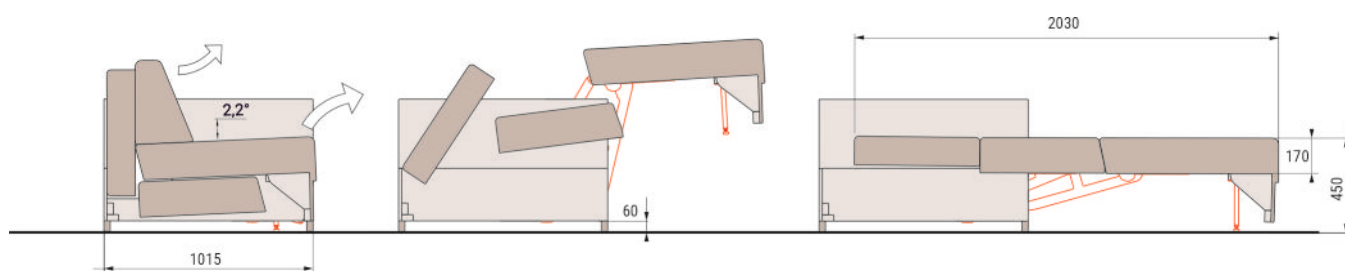

mechanizm PUMA PRO
PF 277-5 MIN 30



PATENT

AKCESORIA WYMAGANE REQUIRED ACCESSORIES

synchronizator
 synchronizing bar

PF 202-AM-5 L=1520 1 MIN 30
 L - na życzenie / at request



sprężyna
 spring

AS 624-1 Fs=1235N 2 MIN 100
AS 637-1 Fs=1050N 2 MIN 100
AS 438-1 Fs=840N 2 MIN 100



AKCESORIA DODATKOWE ADDITIONAL ACCESSORIES

noga podporowa
 supporting leg

NG 319-5 2 MIN 30
 z regulacją wysokości / with height
 adjustment H=244 + max 38



PUMA™ PRO high legs

FUNKCJA SPANIA DO SOFY
SOFA BED FUNCTION

- ✓ Prosta konstrukcja mebla na wysokich nogach
Simple furniture construction on high legs
- ✓ Łatwa obsługa mebla „jednym ruchem”
Easy one-motion operation of the furniture
- ✓ Duża powierzchnia spania
Large sleeping surface
- ✓ Mebel może być dostarczany paczkach
Furniture can be delivered in packages



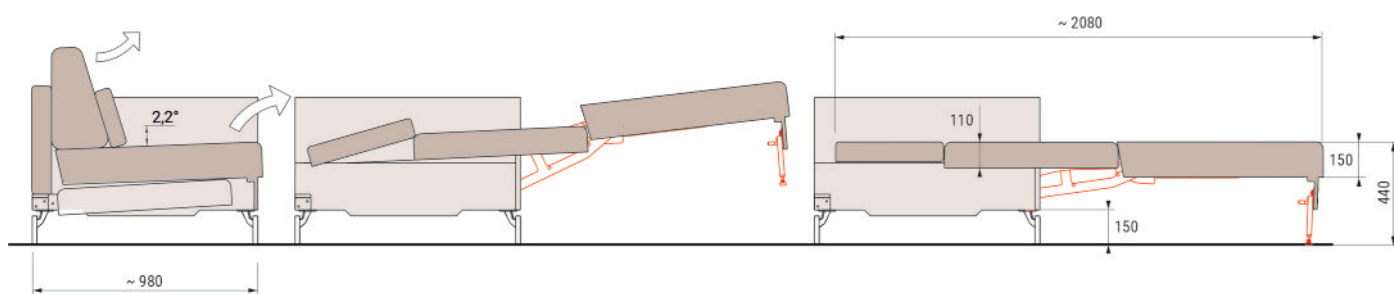

mechanizm PUMA PRO high legs

PF 278-5 MIN 30



PATENT

AKCESORIA WYMAGANE REQUIRED ACCESSORIES

synchronizator
synchronizing bar

PF 202-AM-5 L=1520 1 MIN 30

L - na życzenie / at request



sprężyna
spring

AS 624-1 Fs=1235N 2 MIN 100

AS 637-1 Fs=1050N 2 MIN 100

AS 438-1 Fs=840N 2 MIN 100



AKCESORIA DODATKOWE ADDITIONAL ACCESSORIES

noga automatyczna z regulacją wysokości
automatic leg with height adjustment

● **PF 280-H-5** 1 H=232 + MAX 38 MIN 5

● **PF 280-J-5** 1 H=202 + MAX 38 MIN 5



SLIDE_X

ELEKTRYCZNA FUNKCJA RELAKSU I SPANIA DO SOFY
ELECTRIC RELAXATION AND SLEEPING FUNCTION FOR SOFA

- ✔ Niezawodna i mocna konstrukcja napędu
Reliable and durable drive mechanism
- ✔ Wygodne materace
Comfortable mattresses
- ✔ Łatwa obsługa przez użytkownika
User-friendly operation



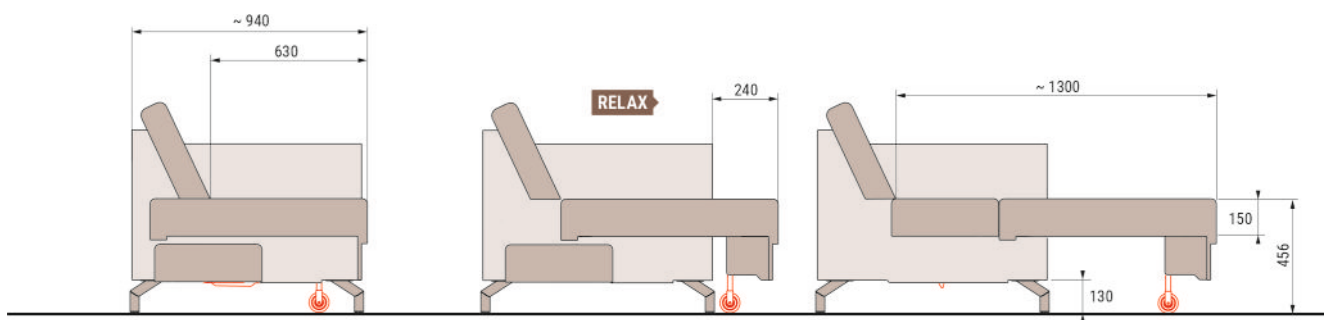

PF 300-5 MIN 30 1

PATENT PENDING



AKCESORIA WYMAGANE
REQUIRED ACCESSORIES

KDPT007-XA 1



AR 253-5 2 MIN 60
duża wytrzymałość / heavy duty



AR 228-1 2 MIN 60



KDH026 2 LUB/OR **KDH107D** 2



AKCESORIA DODATKOWE
ADDITIONAL ACCESSORIES

AK 640-5 1 L=1860 MIN 30
L - na życzenie / at request



SLIDE_S

ELEKTRYCZNA FUNKCJA RELAKSU I SPANIA DO NAROŻNIKA
ELECTRIC RELAXATION AND SLEEPING FUNCTION FOR CORNER SOFA

- ✔ Prosta konstrukcja mebla i niezawodny napęd
Simple furniture construction and reliable mechanism
- ✔ Wygodne materace
Comfortable mattresses
- ✔ Łatwa obsługa przez użytkownika
User-friendly operation



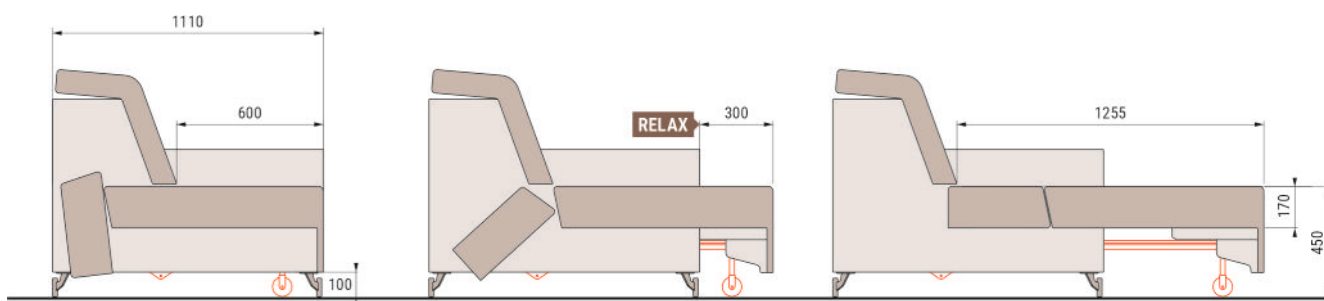

PF 301-A-5 MIN 30

PATENT PENDING



AKCESORIA WYMAGANE
REQUIRED ACCESSORIES

KDPT007-XSA 1

KDH057 1 lub/or KDH026 1 lub/or KDH107D 1



synchronizator
synchronizing bar

● PF 290-A-5 L=1380 ÷ 1440 2 MIN 10

L - wew. szerokość skrzyni / internal box width
regulacja co 10 mm / adjustment every 10 mm



AR 253-5 2 MIN 60
duża wytrzymałość / heavy duty

AR 168-A-1 2 MIN 60



DELFIN_SYSTEM

FUNKCJA SPANIA DO NAROŻNIKA
SLEEPING FUNCTION FOR A CORNER UNIT

- ✓ Prosta zabudowa funkcji w meblu na wysokich nogach
Easy assembly of the mechanism in furniture on high legs
- ✓ Bez ruchomych poduch oparcia
No removable backrest cushions
- ✓ Łatwe rozkładanie funkcji relaksu i spania
Easy operation of relax and sleeping function



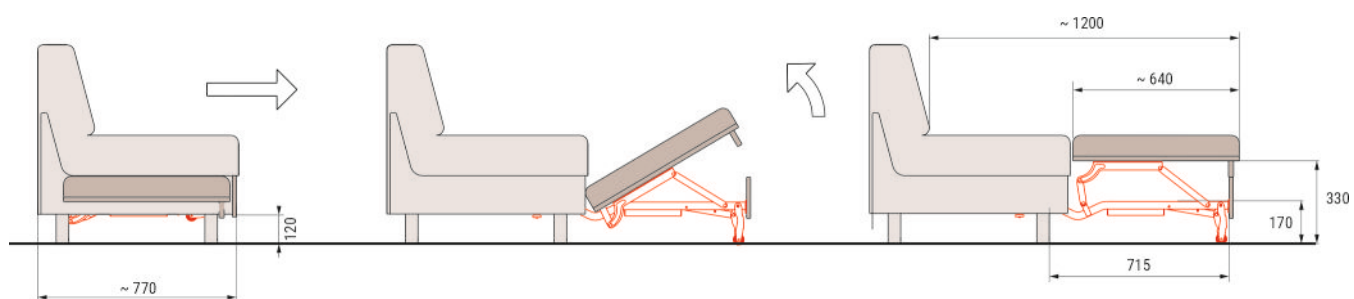

● **WS 189-5** MIN 10

INDUSTRIAL PROPERTY



AKCESORIA WYMAGANE REQUIRED ACCESSORIES

● **WU 573-5** L=1320  0,70  1 MIN 10
L - na życzenie / at request



● **AL 051-5**  1 MIN 100



● **WS 578-5**  1 MIN 10



DELFIN_SYSTEM

FUNKCJA SPANIA DO NAROŻNIKA
SLEEPING FUNCTION FOR CORNER SOFA



● PF 001-B-5 MIN 10

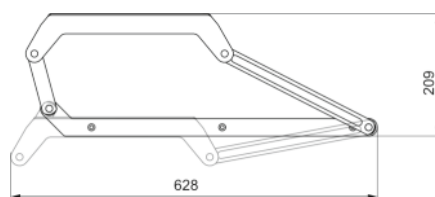

● PF 003-5 MIN 10

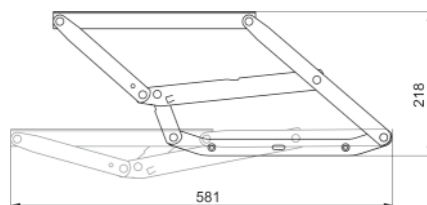

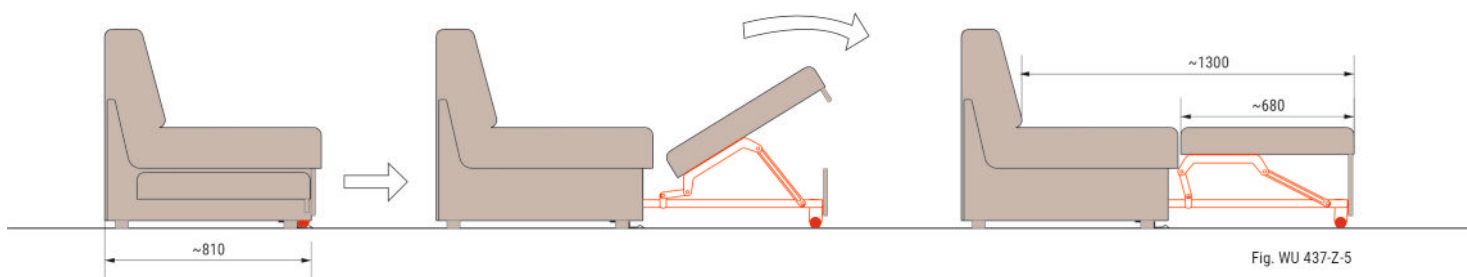

● **WU 437-Z-5** MIN 10

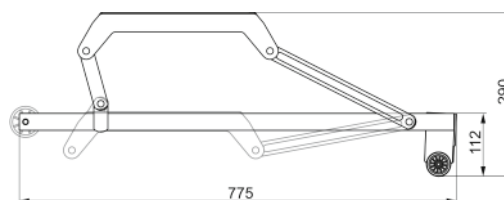

WU 429-D-5 MIN 100

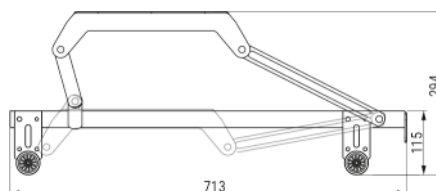

AKCESORIA WYMAGANE REQUIRED ACCESSORIES

WU 573-5 L=1320 ■ 1 MIN 10
L - na życzenie / at request



● **AL 051-5** ■ 1 MIN 100

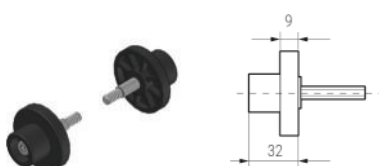

● **AZ 321-1** MIN 100 lub :: or ● **LZ 037-A-5** MIN 200
■ 2



DL_SYSTEM

FUNKCJA SPANIA DO SOFY
SLEEPING FUNCTION FOR SOFA

- ✓ Prosta konstrukcja i łatwa obsługa mebla
Easy construction and easy to use furniture
- ✓ Do mebli na wysokich nogach
For furniture with high legs
- ✓ Sofa może być dostarczana w paczkach
Sofa can be delivered in packages

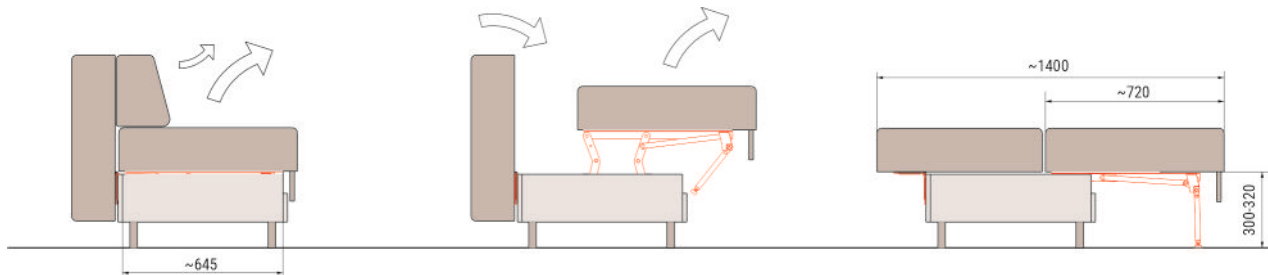

● PF 085-5 MIN 10



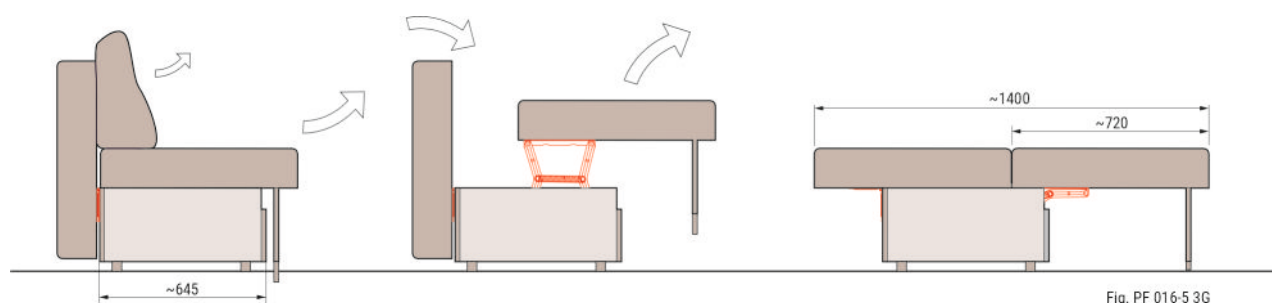
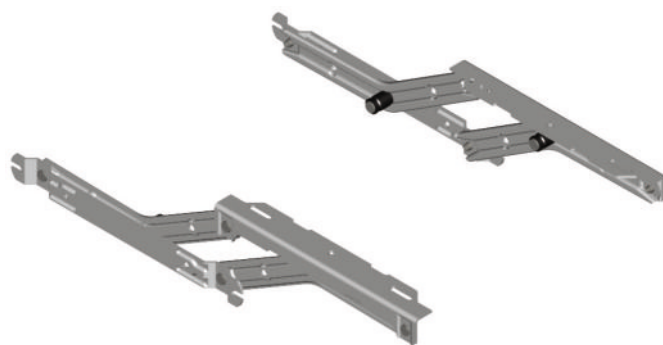

Fig. PF 016-5 3G

- **PF 016-5 3G** W=483 MIN 10
- **PF 022-5** W=600 MIN 10



AKCESORIA WYMAGANE REQUIRED ACCESSORIES

synchronizator teleskopowy
telescopic synchronizing bar

- **CB 029-5-3G** L=1000±1400 1 MIN 10
- **CB 033-5-3G** L=1200±2000 1 MIN 10



sprężyna
spring

- **AS 119-1** F_s=250N 2 MIN 100
- **AS 135-1** F_s=380N 2 MIN 100
- **AS 252-1** F_s=510N 2 MIN 100



zawias
hinge

- **CH 031-1** 2 MIN 100



wsuwka
slide-in-joint

- **CZ 181-1** 2 MIN 100



TAHITI

FUNKCJA SPANIA DO SOFY
SLEEPING FUNCTION FOR SOFA

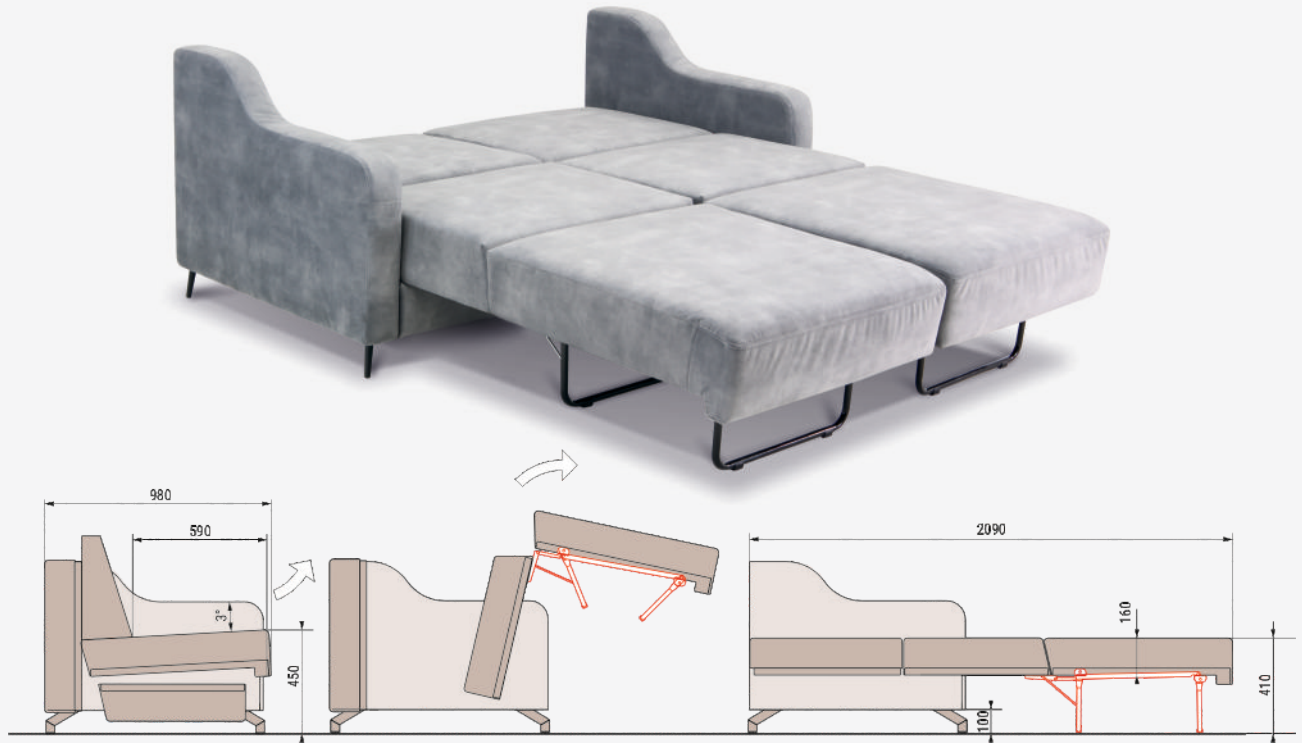

KO 012-5 L=800 MIN 50



KO 013-B-5 L=1540 MIN 50



L = wewnętrzna szerokość skrzyni
L = internal box width

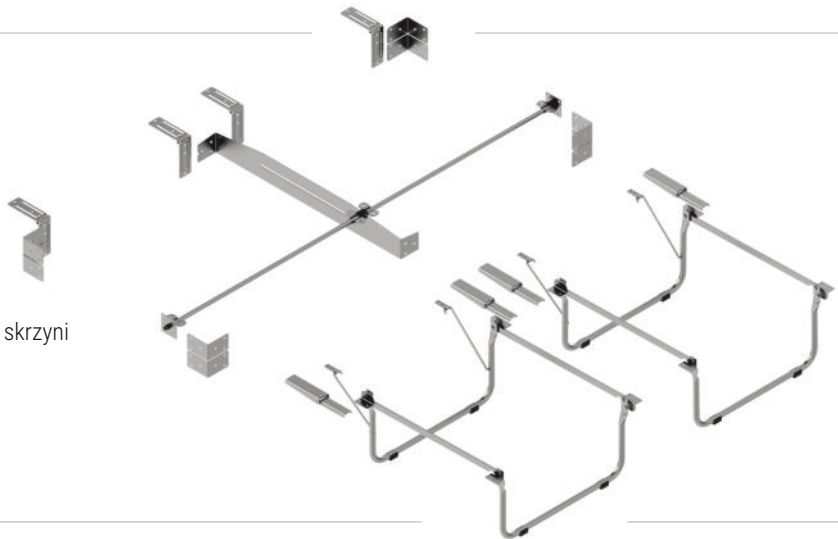

AKCESORIA DODATKOWE ADDITIONAL ACCESSORIES

wspomaganie otwierania
assisted unfolding

KO 128-1 MIN 50

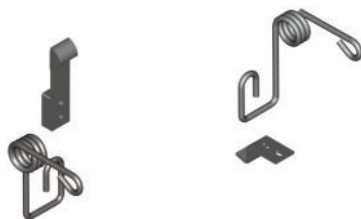

PODNOŚNIKI DO PUFY ZE SCHOWKIEM
LIFTING MECHANISMS FOR STORAGE POUF

● **PC 024-1** MIN 50

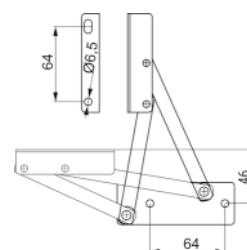
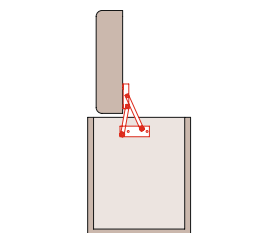

● **PC 025-1** MIN 50

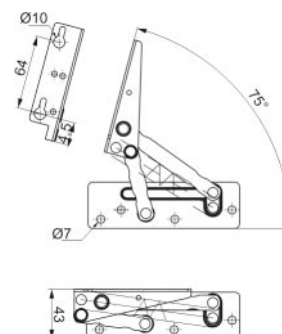
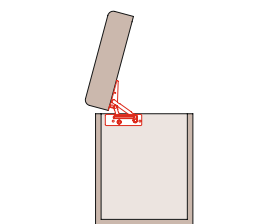

PD 006-1 MIN 200

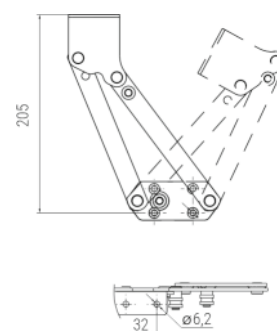
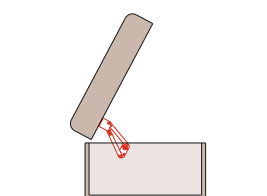

sprężyna
spring

AS 552-1 $F_s=250N$ 2 MIN 200



PODNOŚNIKI DO OTOMAN LEKKICH
LIFTING MECHANISMS FOR LIGHT CORNER SOFA STORAGE

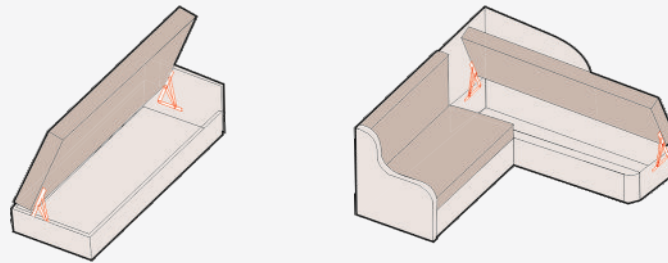

● **PL 134-4** MIN 20

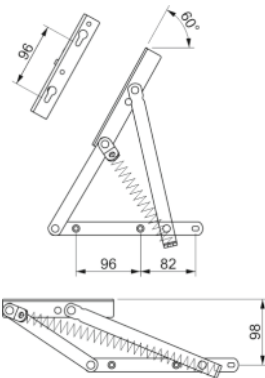

sprężyna naciągowa
regular spring

● **AS 130-1** $F_s=100N$ 2 MIN 100

● **AS 119-1** $F_s=380N$ 2 MIN 100



osłona
plastic cover

● **TO 001-4** 2 MIN 200

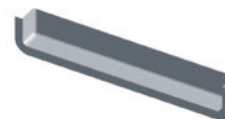

● **PL 001-4** MIN 20

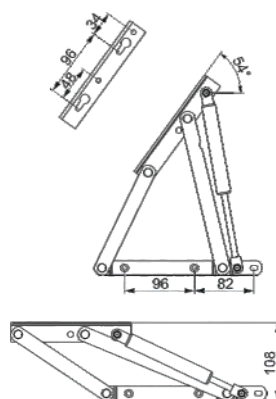

sprężyna gazowa
gas spring

XRA 0160-A $F_s=500N$ 2 MIN 100

zalecane obciążenie 5-25 kG
recommended load 5-25 kG

XRA 0069-A $F_s=800N$ 2 MIN 100

zalecane obciążenie 25-40 kG
recommended load 25-40 kG



PODNOŚNIKI DO OTOMAN ŚREDNICH
LIFTING MECHANISMS FOR MEDIUM CORNER SOFA STORAGE

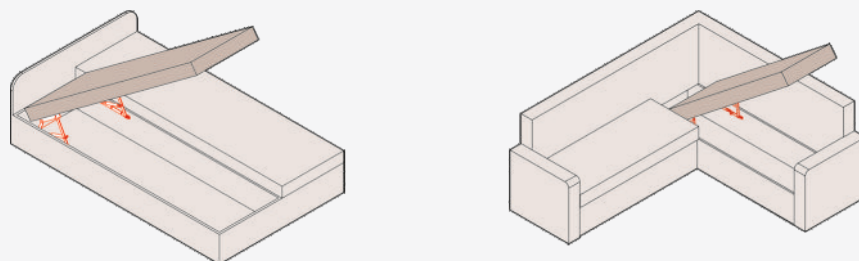

● **PM 142-4** MIN 20

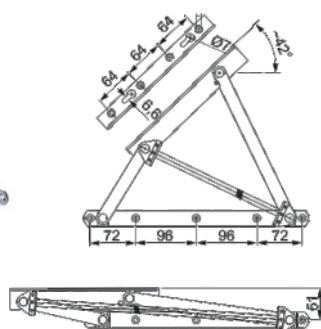

sprężyna naciągowa
regular spring

● **AS 130-1** $F_s=140N$ 2 lub / or 4 MIN 100

AS 105-1 $F_s=305N$ 2 lub / or 4 MIN 100

AS 477-1 $F_s=510N$ 2 lub / or 4 MIN 100



osłona
plastic cover

● **TO 002-4** 2 MIN 200

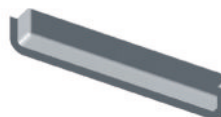

● **PM 147-4** MIN 20

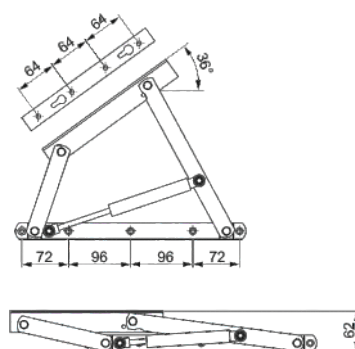

sprężyna gazowa
gas spring

XRA 0160-A $F_s=500N$ 2 MIN 100

zalecane obciążenie 5-15 kG
recommended load 5-15 kG

XRA 0069-A $F_s=800N$ 2 MIN 100

zalecane obciążenie 12-25 kG
recommended load 12-25 kG



PODNOŚNIKI DO OTOMAN CIĘŻKICH
LIFTING MECHANISMS FOR HEAVY CORNER SOFA STORAGE

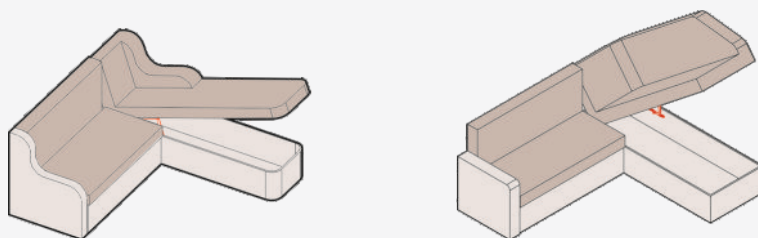

● **PZ 182-4** MIN 10

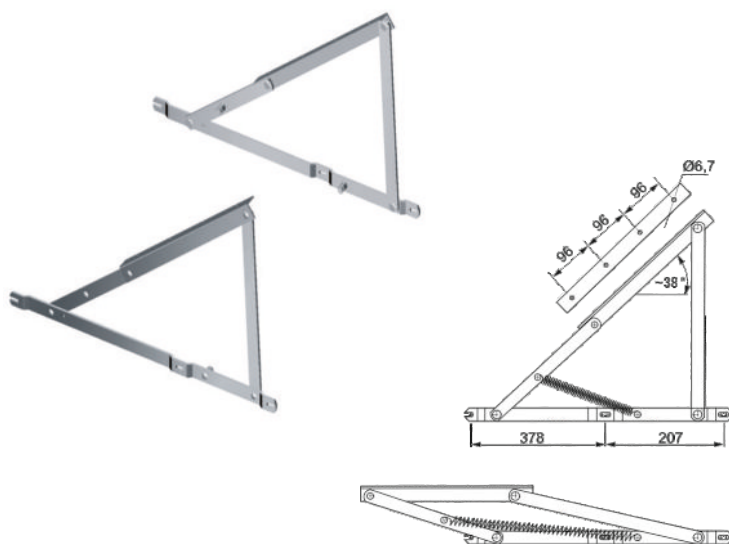

sprężyna naciągowa
regular spring

● **AS 129-1** $F_s=360N$ 2 MIN 50

● **AS 126-1** $F_s=550N$ 2 MIN 50

● **AS 109-1** $F_s=660N$ 2 MIN 50

● **AS 108-1** $F_s=900N$ 2 MIN 50



osłona
plastic cover

● **TO 003-4** 2 MIN 125



● **PZ 180-4** MIN 10

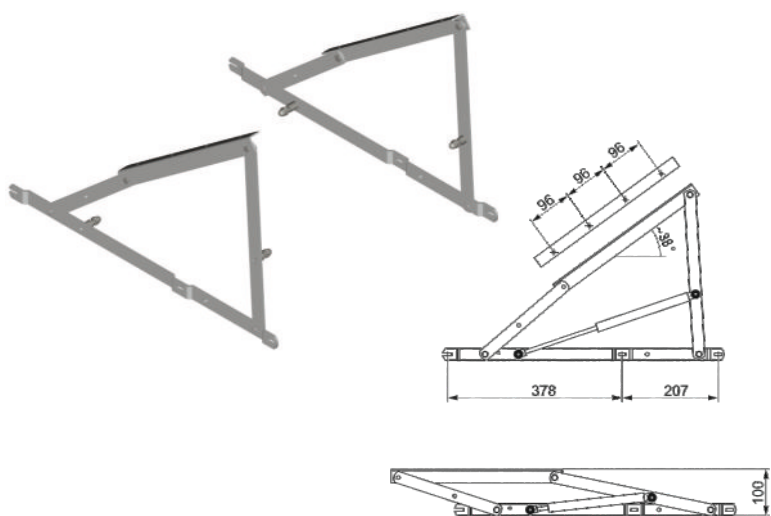

sprężyna gazowa
gas spring

● **XRA 0045-A** $F_s=500N$ 2 MIN 100

zalecane obciążenie 12-22 kG
recommended load 12-22 kG

● **XRA 0083-A** $F_s=700N$ 2 MIN 40

zalecane obciążenie 17-32 kG
recommended load 17-32 kG

● **XRA 0168-A** $F_s=1000N$ 2 MIN 40

zalecane obciążenie 24-45 kG
recommended load 24-45 kG



PODNOŚNIKI DWUFUNKCYJNE DO ŁÓŻKA
DOUBLE FUNCTION MECHANISMS FOR BED

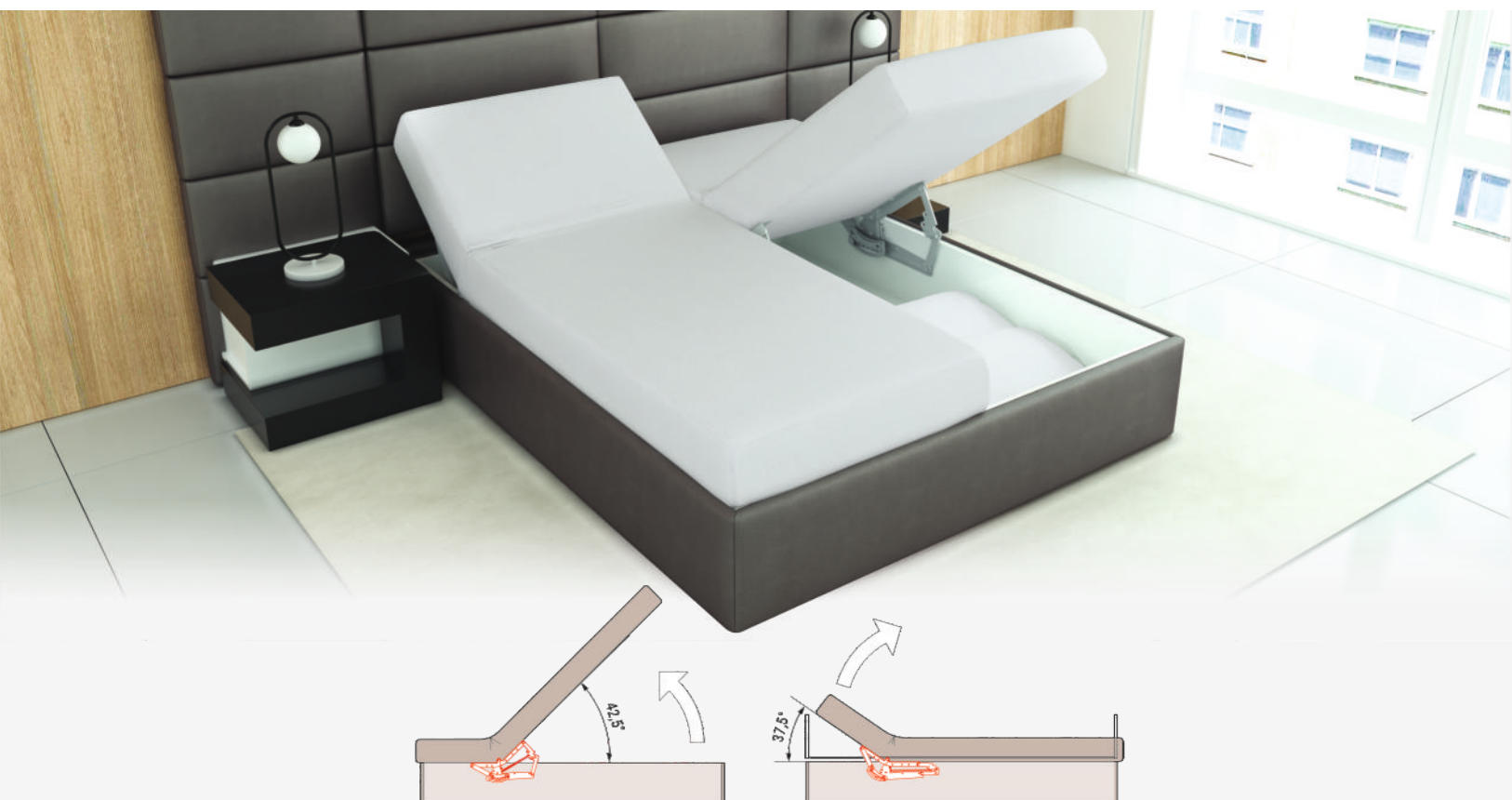

● **PD 122-1** MIN 10



● **AS 138-1** 2 MIN 100
sprężyna naciągowa / regular spring



PD 126-B-1 MIN 200

INDUSTRIAL PROPERTY



XRA 0083-A $F_s=700N$ 2 MIN 40
sprężyna gazowa / gas spring





rama składana do montażu własnego
bolted frame for self assembly

RU 820-5 1380 X 2000 MIN 48

RU 820-A-5 1580 X 2000 MIN 48

RU 820-B-5 1780 X 2000 MIN 48

ilość listew **34** number of slats **34**

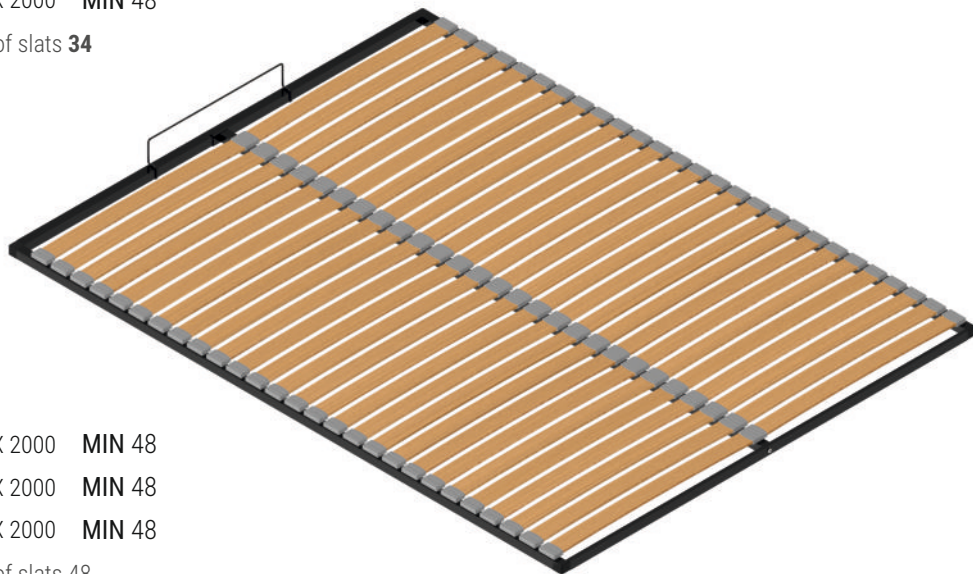

RU 821-5 1380 X 2000 MIN 48

RU 821-A-5 1580 X 2000 MIN 48

RU 821-B-5 1780 X 2000 MIN 48

ilość listew **48** number of slats **48**

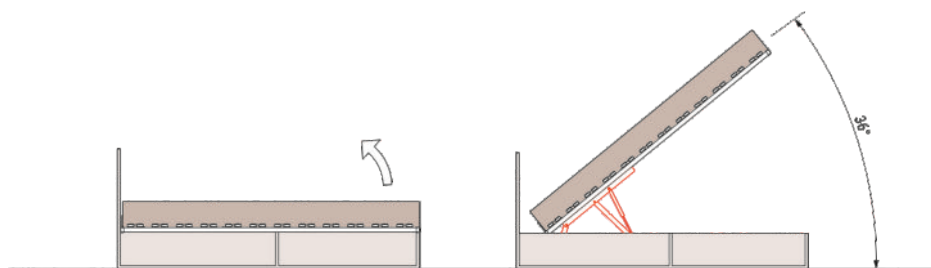

podnośnik łóżka
bed lifting mechanism

● **PZ 217-A-5** MIN 5



sprężyna gazowa
gas spring

XRA 0118-A $F_s=900N$ 2 MIN 100

Zalecane obciążenie 25-45 kG Recommended load 25-45 kG

XRA 0046-A $F_s=1000N$ 2 MIN 100

Zalecane obciążenie 30-50 kG Recommended load 30-50 kG

XRA 0064-A $F_s=1150N$ 2 MIN 100

Zalecane obciążenie 35-60 kG Recommended load 35-60 kG



AKCESORIA DODATKOWE ADDITIONAL ACCESSORIES

AK 087-1 MIN 200



● **CK 028-5** MIN 35

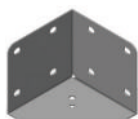

● **AK 131-1** MIN 20



CK 017-5 MIN 200



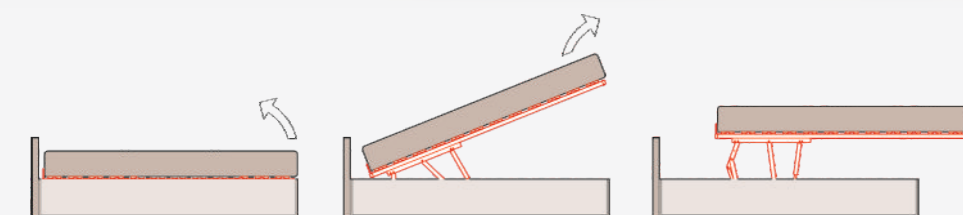

podnośnik dwufunkcyjny do łóżka
double-function bed lifting mechanism

PZ 245-5 MIN 50

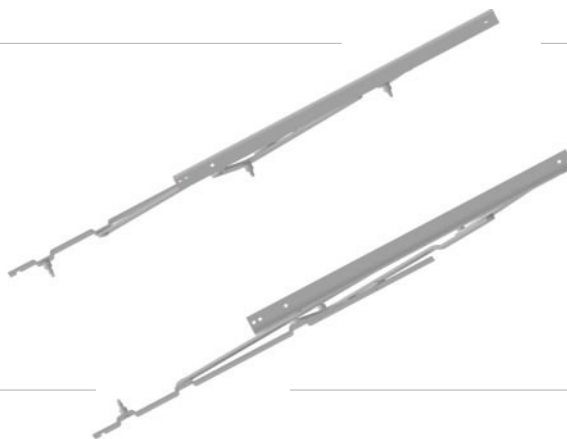

AKCESORIA WYMAGANE
REQUIRED ACCESSORIES

sprężyna gazowa
gas spring

XRA 0129 $F_s=700N$ 2 MIN 50

zalecane obciążenie 45-55 kG recommended load 45-55 kG

XRA 0128 $F_s=900N$ 2 MIN 50

zalecane obciążenie 55-65 kG recommended load 55-65 kG



synchronizator
synchronizing bar

CB 033-5-3G $L=1200\pm 2000$ 1 MIN 10



EASY SLIDE

OKUCIA DO WYSUWU SIEDZISKA
FITTINGS TO EXTEND THE SEAT

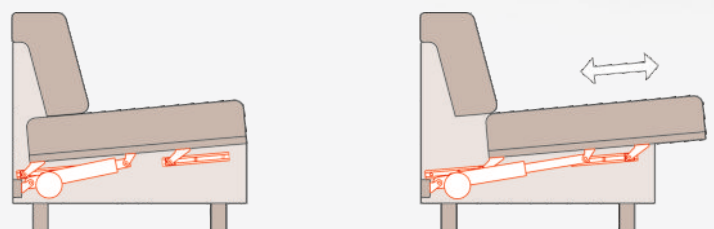

KDYJT013-A-X skok 255mm stroke 255mm 📏 1



KDH057 📏 1 lub/or **KDH026** 📏 1 lub/or **KDH107D** 📏 1



● **AK 442-1** 📏 2 MIN 100



● **AR 006-A-1** 📏 2 MIN 50

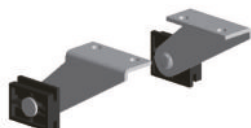

AP 046-1 L=300 📏 4 MIN 200

AP 041-1 L=230 📏 4 MIN 200

L - na życzenie / at request



WAVE

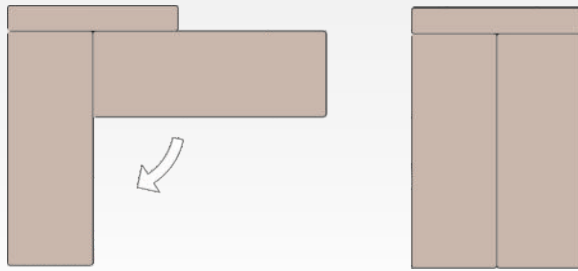

obrotnica
swivel mechanism

● **PB 031-5** MIN 5

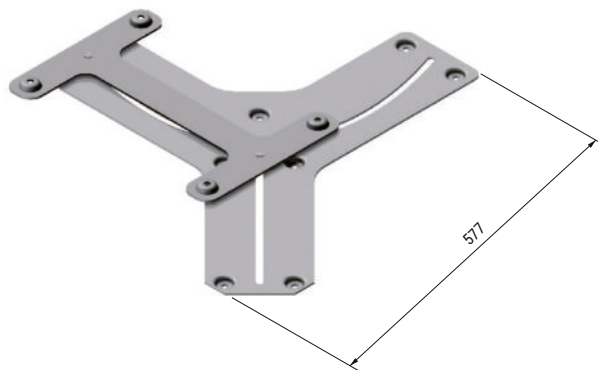

SPINNER



obrotnica
swivel mechanism

PATENT

● **PB 041-B-5** MIN 10

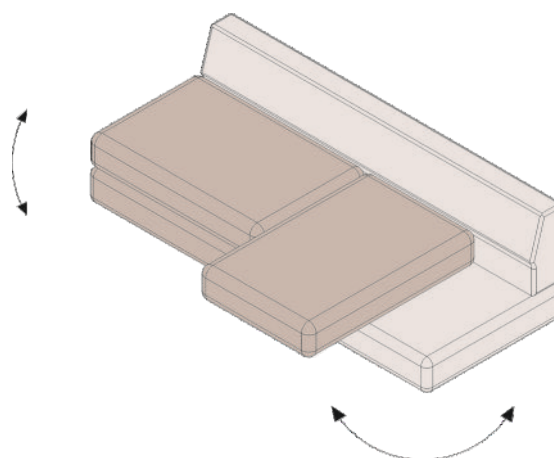
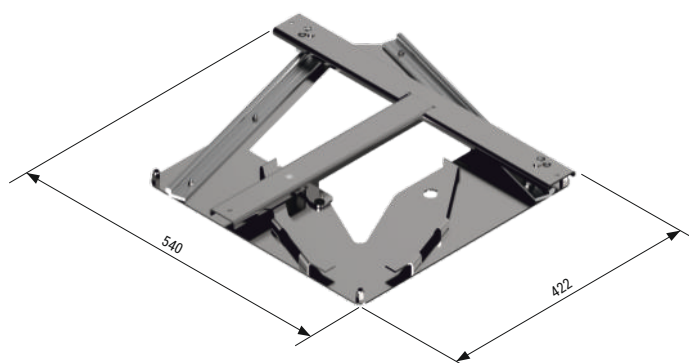

MECHANIZM PODNÓŻKA Z SILNIKIEM
FOOTREST MECHANISM WITH MOTOR

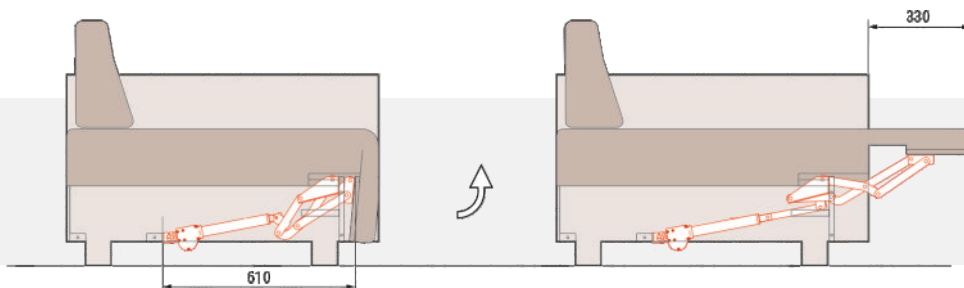

SF 121-5 MIN 50

KDYJT013-B-X skok 175mm stroke 175mm 1



KDH026 1

KDH057 1

KDH107D 1



MECHANIZM PODNÓŻKA Z SILNIKIEM
FOOTREST MECHANISM WITH MOTOR

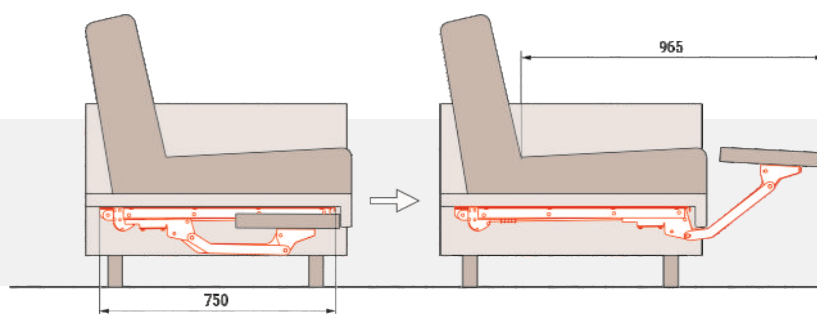

SF 124-5 MIN 60 PATENT

KDPT007N-246-X 1



SF 122-5 MIN 60
manualny mechanizm podnóżka
manual footrest mechanism

KDH026 1

KDH057 1

KDH107D 1



MECHANIZMY OPARCIA
BACKREST MECHANISMS

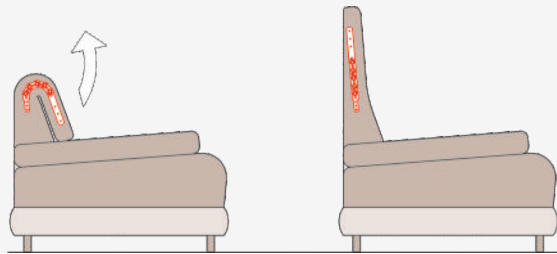

PP 270-1 MIN 100
moment sily 7 Nm
torque of 7 Nm



MECHANIZMY OPARCIA
BACKREST MECHANISMS

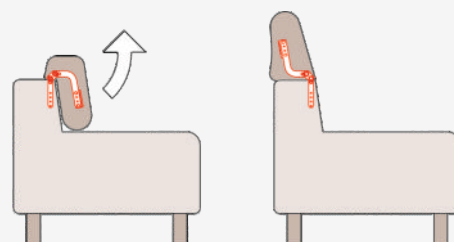

PP 812-1 MIN 100
moment siły 7 Nm
torque of 7 Nm



MECHANIZMY OPARCIA
BACKREST MECHANISMS

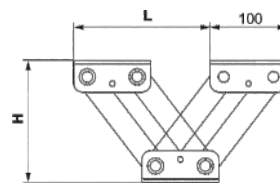
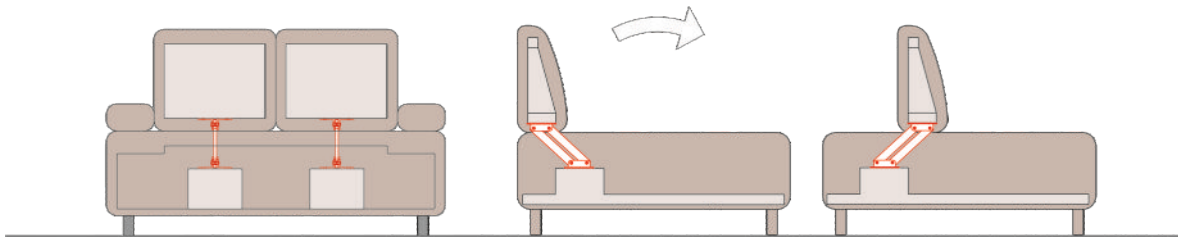

Kod wyrobu Product Code	L [mm]	H [mm]	F [Nm]	MIN MIN
● PB 033-1	260	150	4,5	20
PB 033-I-1	188	117	4,5	100



MECHANIZMY OPARCIA
BACKREST MECHANISMS

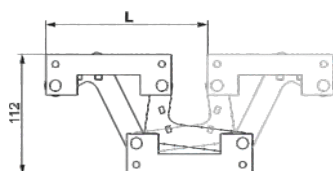
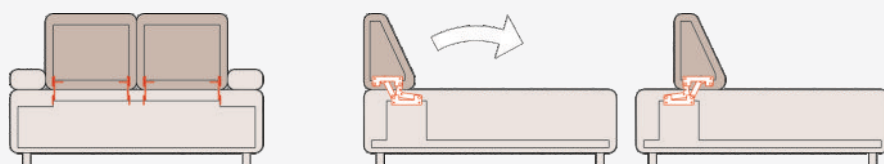

Kod wyrobu Product Code	L [mm]	MIN MIN
PC 136-F-1	153	90
PC 136-A-1	182	90

MECHANIZMY OPARCIA
BACKREST MECHANISMS

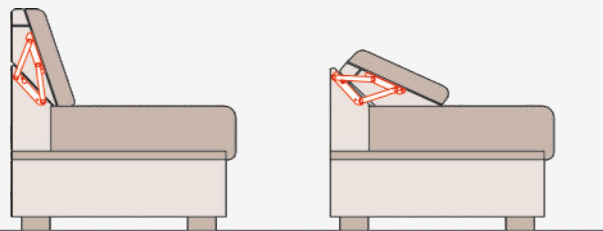

● **PC 026-1** MIN 20

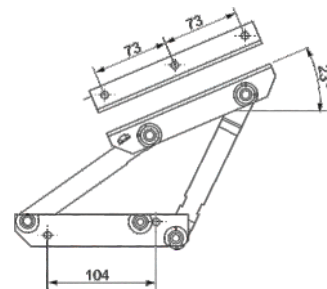

SOLIDMATIC

PRZEGUB STOPNIOWY DO **OPARCIA**
RATCHET MECHANISM FOR **BACKREST**

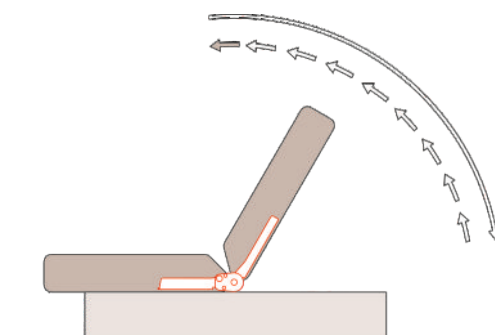

Maksymalny moment siły **2 x 300 Nm**
Maximum torque **2 x 300 Nm**

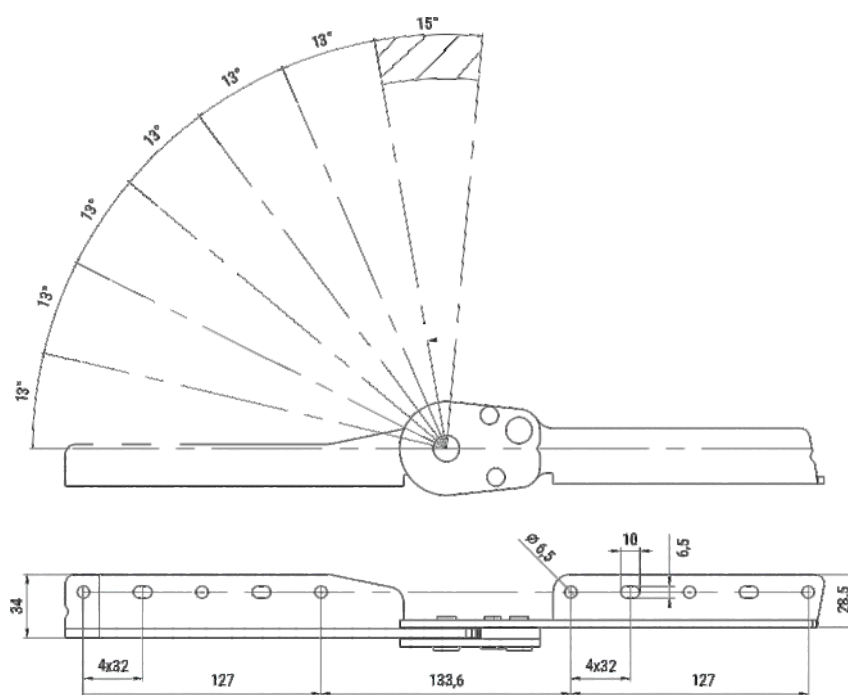

Kod wyrobu Product Code	Położenie początkowe Initial position	Położenie końcowe Final position	Ilość położeń No. of positions	Jednostka Unit	MIN MIN
PP 555-N-1	180°	260°	6	para / pair	90

FLEXMATIC

PRZEGUB STOPNIOWY DO **PODŁOKIETNIKA / ZAGŁÓWKA**
 RATCHET MECHANISM FOR **ARMREST / HEADREST**



Maksymalny moment siły **150 Nm/szt**
 Maximum torque **150 Nm/pc**

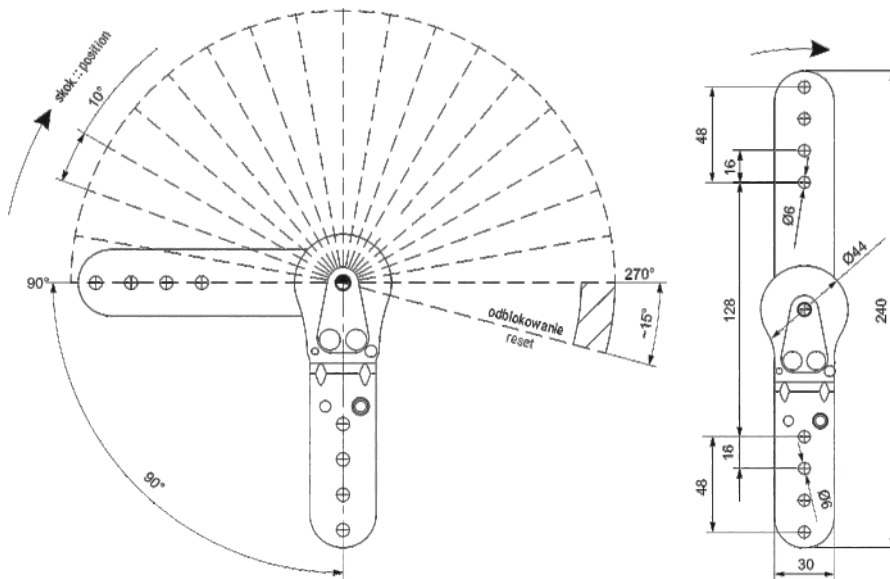

Kod wyrobu Product Code	Położenie początkowe Initial position	Położenie końcowe Final position	Jednostka Unit	MIN MIN	Uwagi Note
PP 150-1	90°	170°	szt / pc	100	Położenie na zamówienie Positions at request

SPOSÓB MOCOWANIA **KĄTOWNIKÓW** DO PRZEGUBÓW - DO WYBORU
ANGLE BRACKET FITTING METHOD - OPTIONS

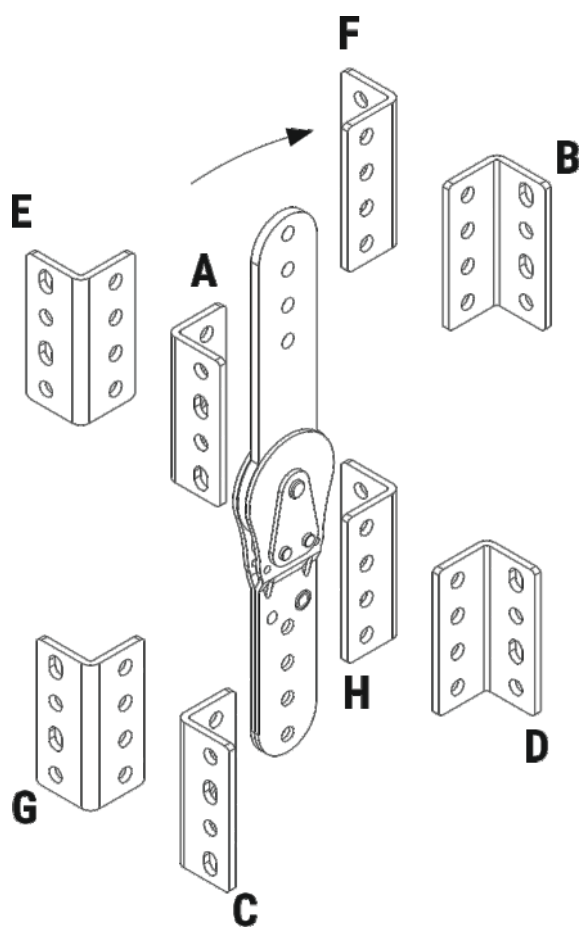

kątownik standardowy standard bracket angle

● **AK 133-1** MIN 200

montaż na wsuwki assembly with slide-in joints

AL 094-1 MIN 200

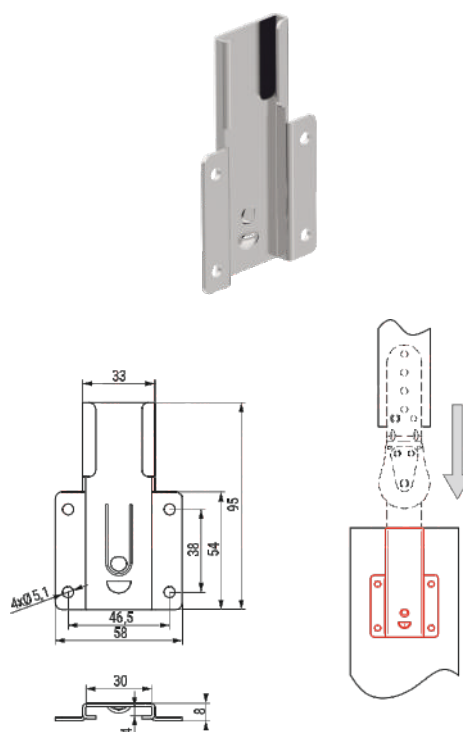
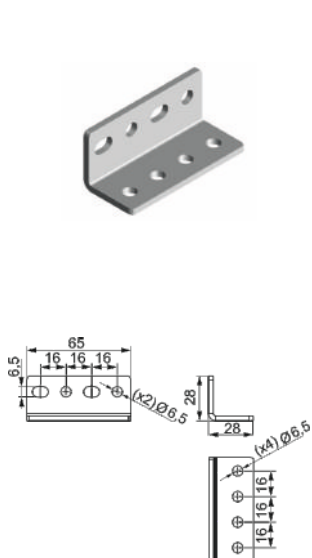

STRETCHMATIC

PRZEGUB STOPNIOWY DO ZAGŁÓWKA Z FUNKCJĄ NAPINANIA
 RATCHET MECHANISM FOR HEADREST WITH STRETCHING FUNCTION

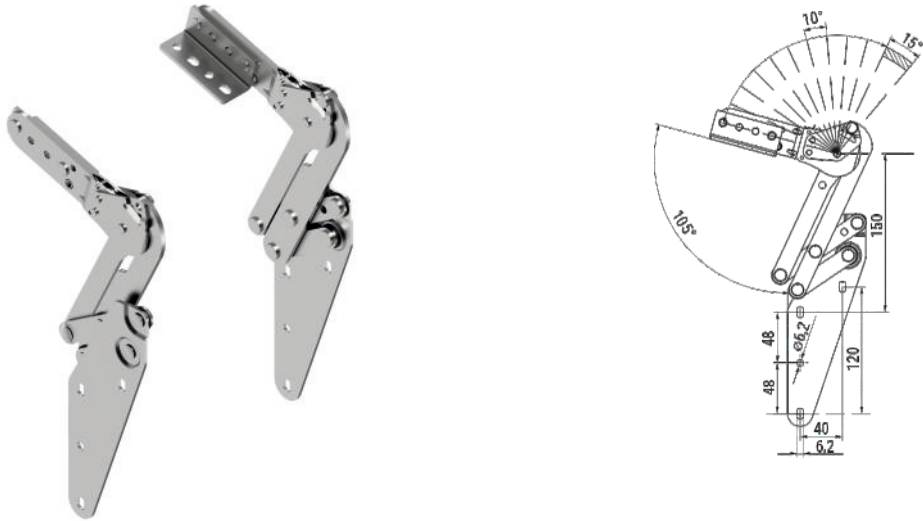

Maksymalny moment siły **2 x 80 Nm** Maximum torque **2 x 80 Nm**

Kod wyrobu Product Code	Napinanie Stretching	Położenie początkowe Initial position	Położenie końcowe Final position	Jednostka Unit	MIN MIN
PP 241-1	~80mm	105°	195°	para / pair	100

FRIMATIC

PRZEGUB CIERNY DO ZAGŁÓWKA
FRICTION MECHANISM FOR HEADREST

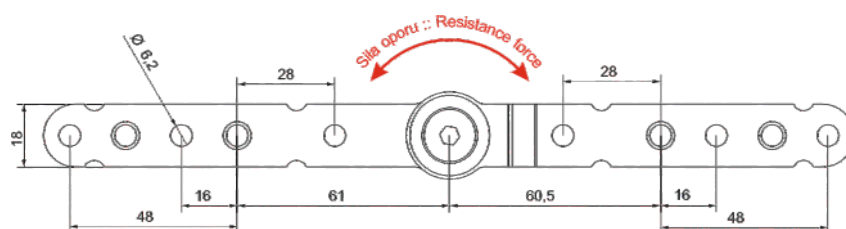

Kod wyrobu Product Code	Siła oporu (Nm/szt) Resistance force (Nm/pc)	Jednostka Unit	MIN MIN
PP 343-J-1	10	szt/pc	100

MECHANIZMY ZAGŁÓWKA HEADREST MECHANISMS

● **PP 510-8**  0,60 MIN 25

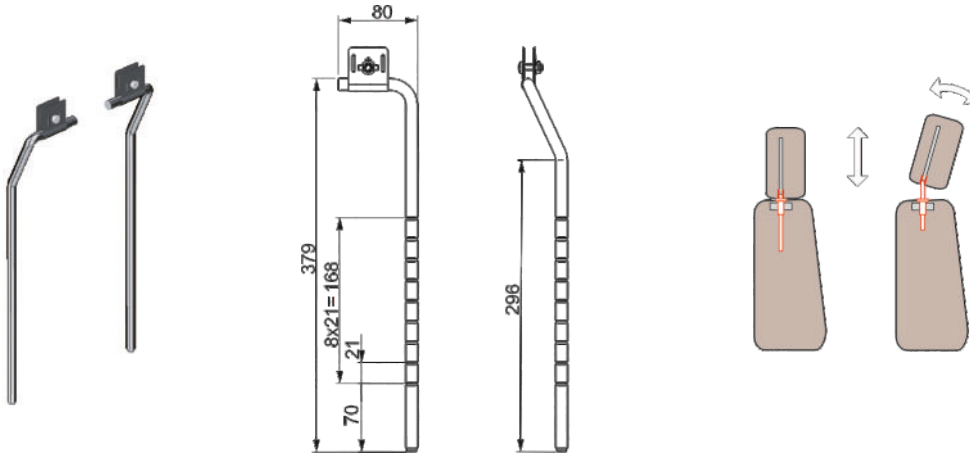

AKCESORIA WYMAGANE REQUIRED ACCESSORIES

- **TS 168-8** MIN 200 sprężyna słaba soft spring
- **TS 169-8** MIN 200 sprężyna średnia medium spring

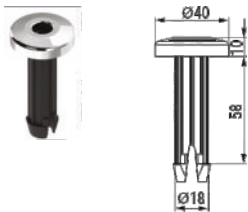

dostępne w wykończeniu czarnym -5
available in black finishing - 5



SZ 318 155° - 207° MIN 100
SZ 317-A 90° - 194° MIN 100

z przegubem stopniowym
 with ratchet mechanism

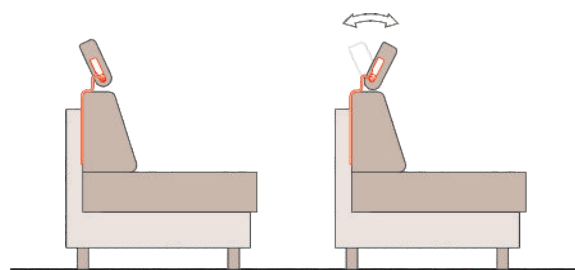
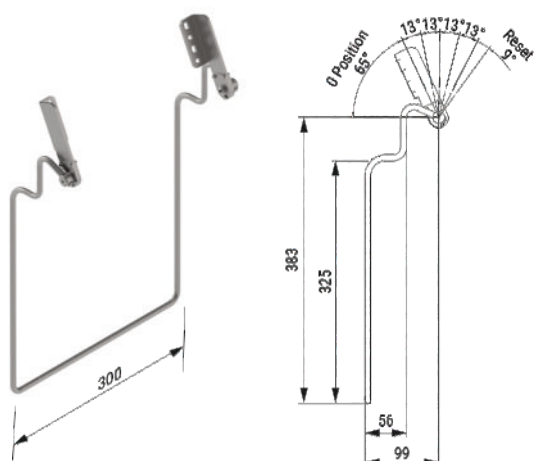

Maksymalne obciążenie
 Maximum load **40 Nm**

● **SZ 509-E-8** MIN 50

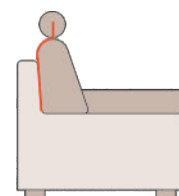
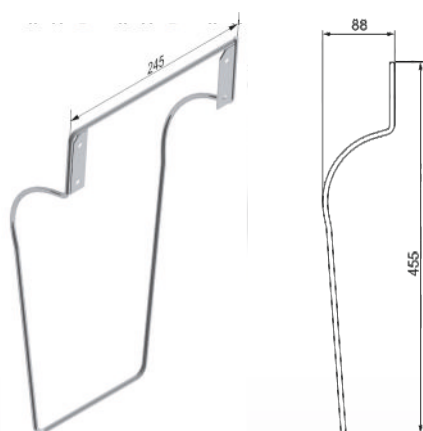

ELEKTRYCZNY MECHANIZM ZAGŁÓWKA
MOTORIZED HEADREST MECHANISM

PC 146-5 MIN 40

z funkcją napinania
with stretching function

INDUSTRIAL PROPERTY

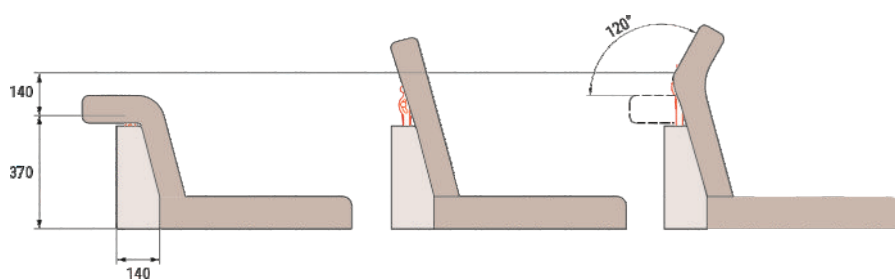
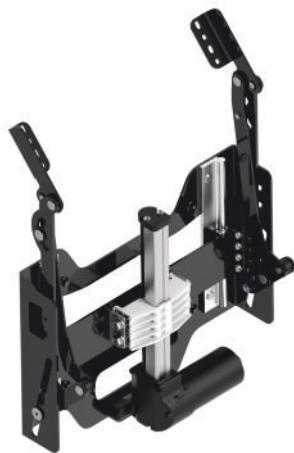

AKCESORIA WYMAGANE
REQUIRED ACCESSORIES

KDH057 1



KDH026 1



KDH107D 1



ELEKTRYCZNY MECHANIZM ZAGŁÓWKA
MOTORIZED HEADREST MECHANISM

PC 150 MIN 40 PATENT PENDING

wykończenia ozdobne -8, -12
decorative finishings -8, -12

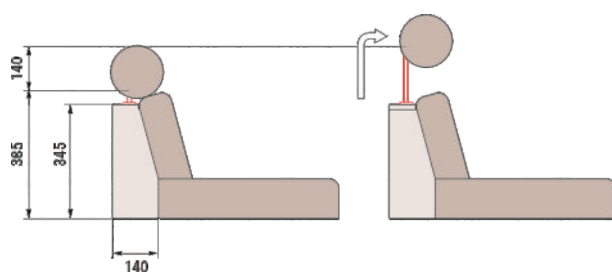

AKCESORIA WYMAGANE
REQUIRED ACCESSORIES

KDH057 1



KDH026 1



KDH107D 1



MECHANIZMY **STOLIKA**
TABLE MECHANISMS



PT 011-P-5 MIN 100

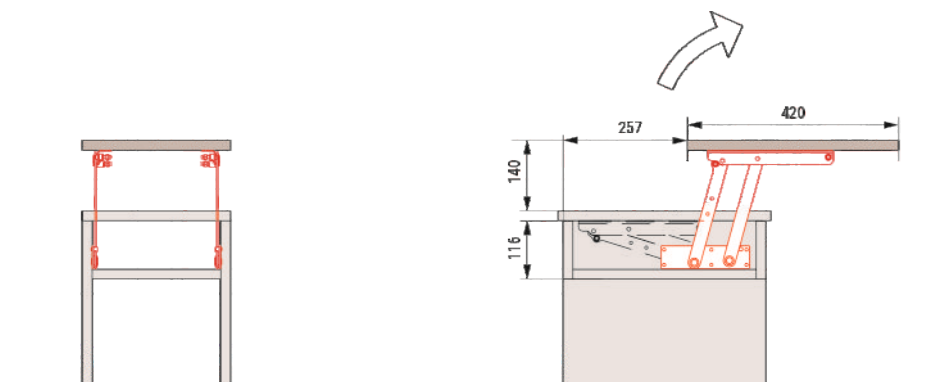

AKCESORIA DODATKOWE
ADDITIONAL ACCESSORIES

PC 090-I-5 L=899  1 MIN 100

L - na życzenie / at request



AKCESORIA WYMAGANE
REQUIRED ACCESSORIES

sprężyna gazowa
gas spring

XRA 0213 $F_s=150N$  2 MIN 100

zalecana waga blatu 6,5 - 11 kg
recommended countertop weight 6,5 - 11 kg

XRA 0115 $F_s=300N$  2 MIN 100

zalecana waga blatu 8 - 14 kg
recommended countertop weight 8 - 14 kg



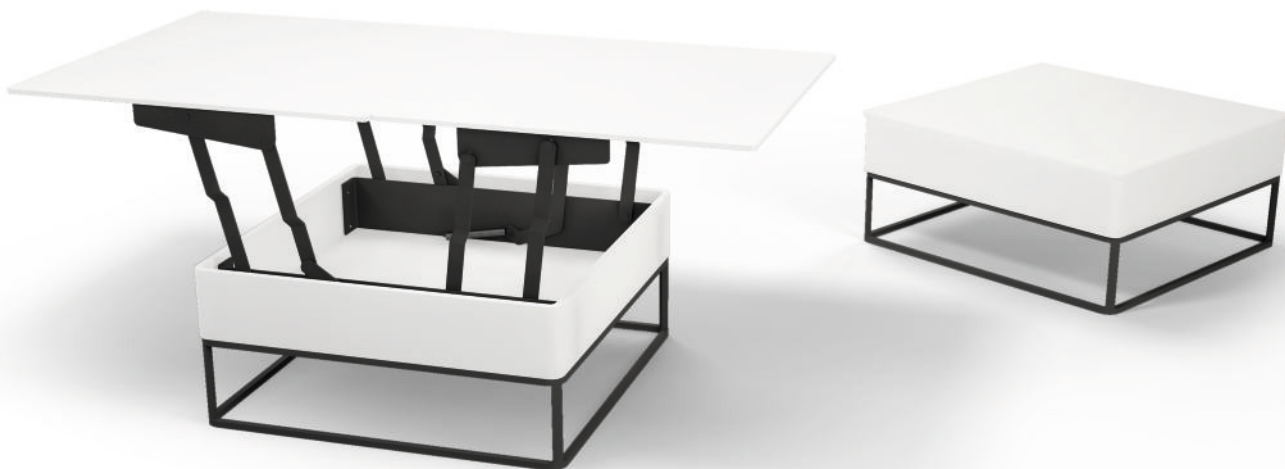

● **PT 009-5** MIN 40

zalecana waga 2 blatów 16÷24 kg recommended weight of 2 countertops 16÷24 kg

INDUSTRIAL PROPERTY

● **PT 009-C-5** MIN 60

z ręczną blokadą położenia with manual position blockade

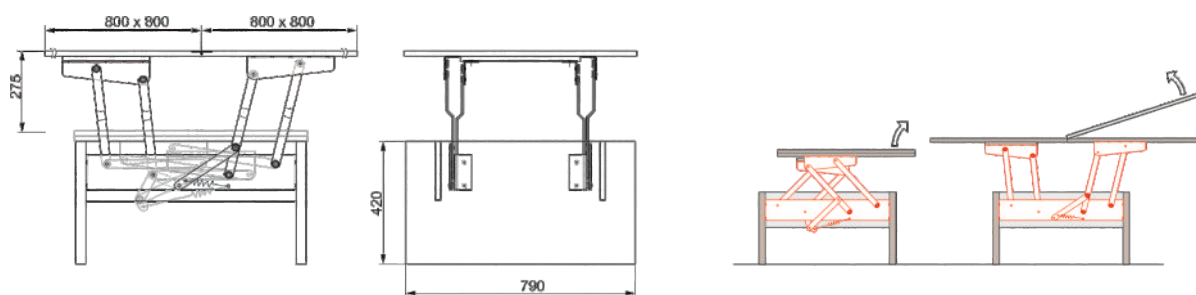

● **AS 119-1** $F_s=395\text{ N}$ 2 MIN 100



MECHANIZMY **STOLIKA**
TABLE MECHANISMS

MK 083-8 MIN 50

PATENT PENDING

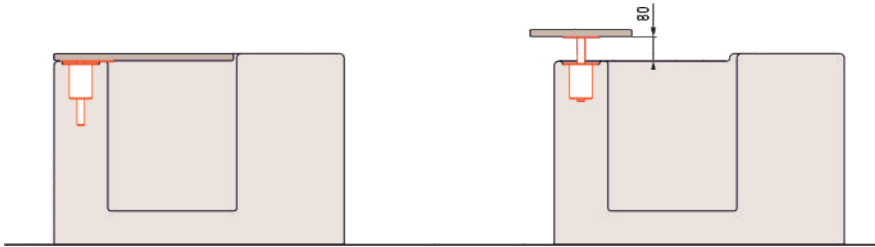

obrót z uniesieniem
turn and lift up

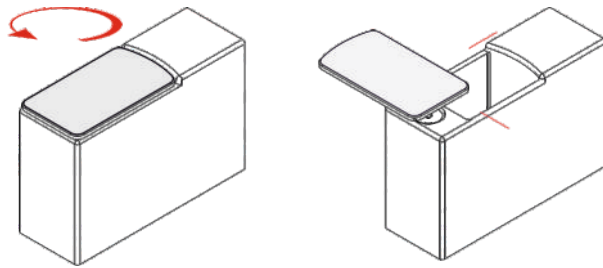

OKUCIA DROBNE :: FITTINGS

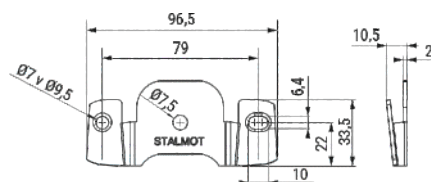
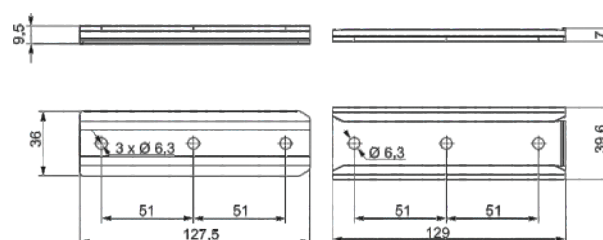
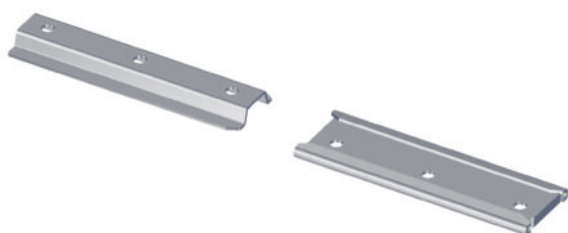
● **AL 034-1** MIN 200● **AL 011-1** MIN 100● **AL 200-1** MIN 100

łącznik klinowy
knock-down bracket

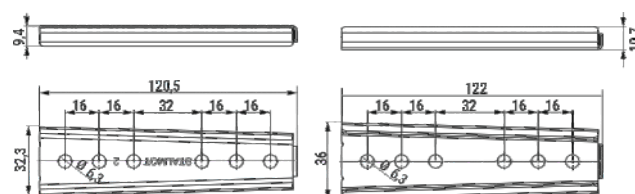

● **AH 001-1** MIN 200

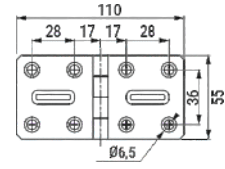

AH 025-1 MIN 400

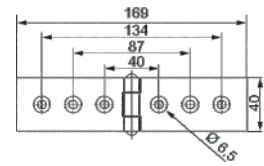

CH 009-1 MIN 400

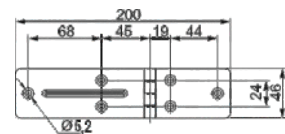

● **CH 031-1** MIN 100

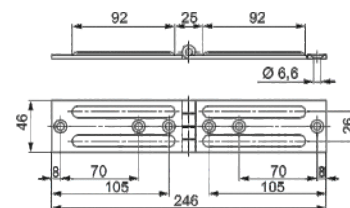

● **CZ 181-1** MIN 100

wsuwka współpracuje z CH 031-1
slide-in-joint co-works with CH 031-1

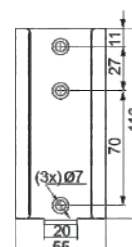

● **AH 055-4** MIN 25

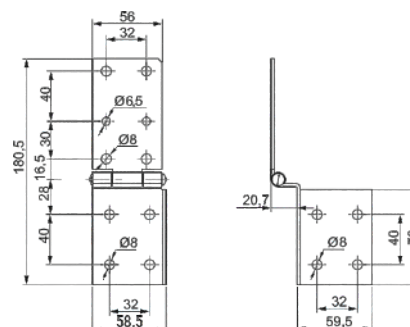

● **AH 050-1** MIN 100

oparcie pod kątem 4°
backrest angle 4°

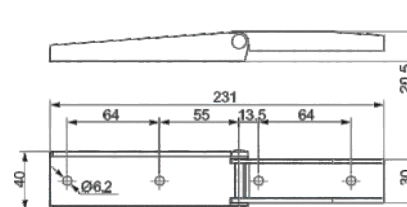

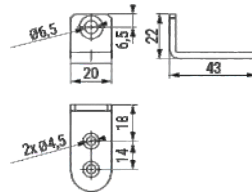
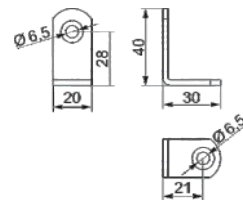
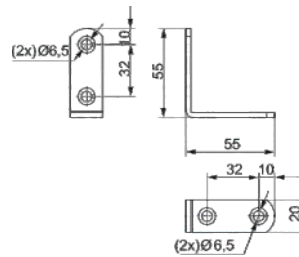
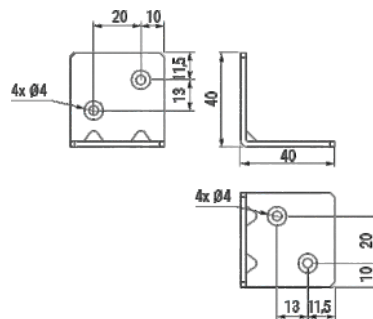
AK 003-1 MIN 400**AK 006-1** MIN 1000**AK 012-1** MIN 400**AK 034-1** MIN 300

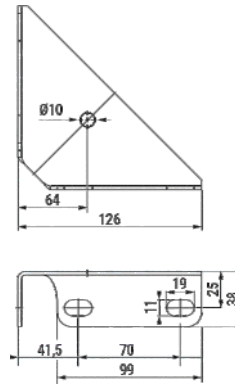
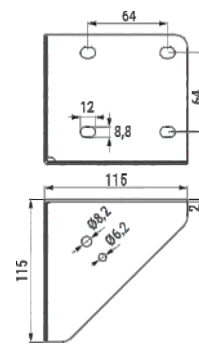
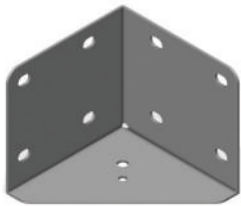
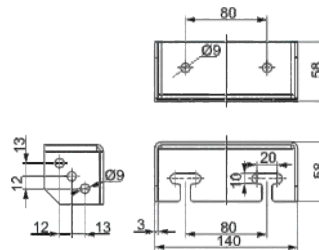
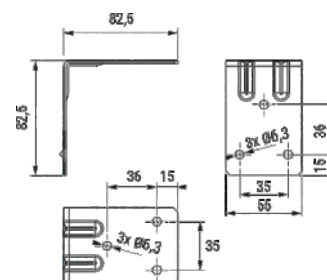
AK 087-1 MIN 200**CK 028-5** MIN 35**AK 131-1** MIN 20**CK 017-5** MIN 200

AR 110-1 PP MIN 500
AR 174-1 PP+Elastomer MIN 500

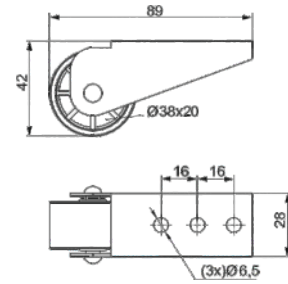

AR 189-1 PP+Elastomer MIN 500

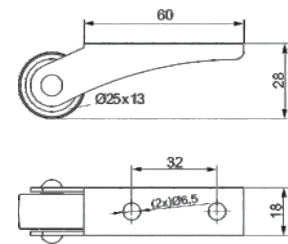

AR 109-1 PP MIN 500
AR 165-1 PP+Elastomer MIN 100

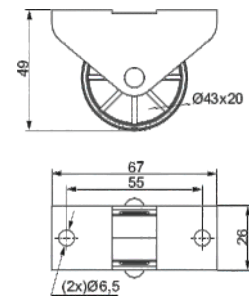

AR 172-1 PP+Elastomer MIN 100

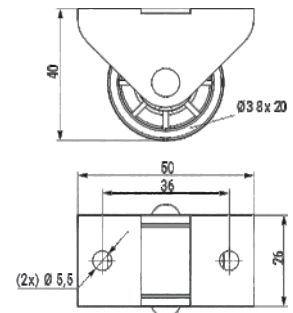

AR 108-1 MIN 500

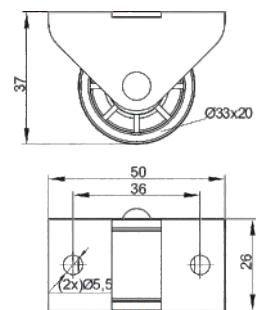

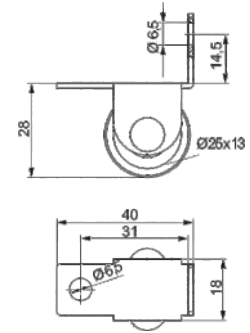
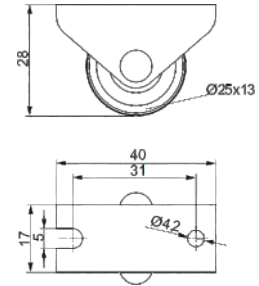
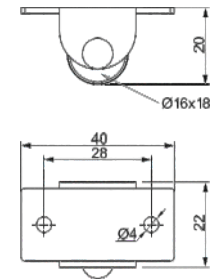
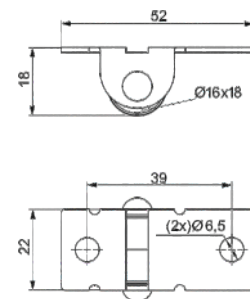
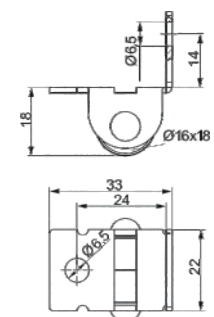
AR 205-1 PP+Elastomer MIN 500**AR 190-1** PP+Elastomer MIN 500**AR 104-1** MIN 100**AR 105-1** MIN 500**AR 101-1** MIN 100

● **AR 168-1** PP+Elastomer MIN 100

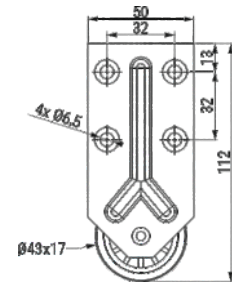

● **AR 115-1** PP MIN 500

● **AR 167-1** PP+Elastomer MIN 100

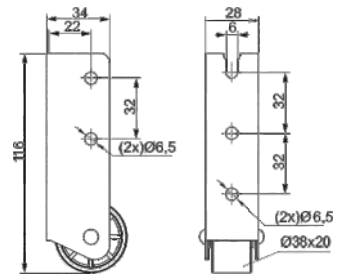

● **AR 116-1** MIN 100

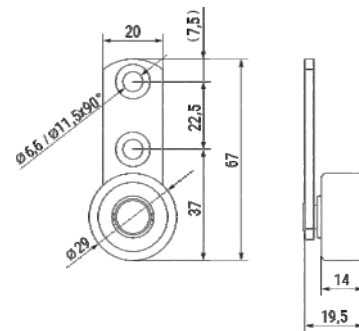

● **LZ 037-A-5** MIN 200

tworzywo
plastic

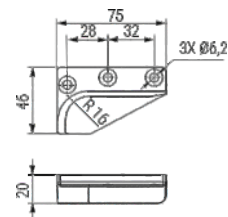

● **AZ 321-1** MIN 100

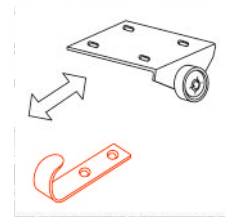
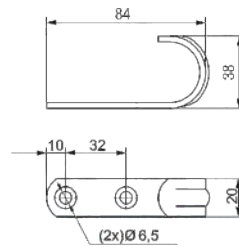

● **AZ 326-1** MIN 100

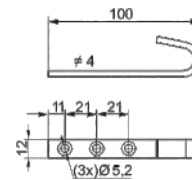

● **AZ 359-1** a=123 h=13 MIN 200

ogumienie
with rubber

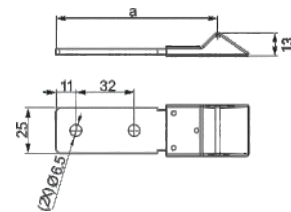

AZ 357-1 a=78 h=28 Ø43 MIN 400

ogumienie
with rubber

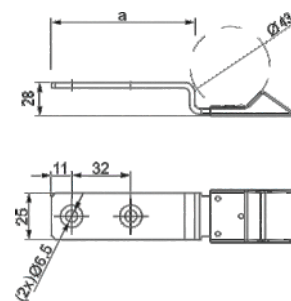

CZ 149-B-1 MIN 100
CZ 149-C-1 MIN 100

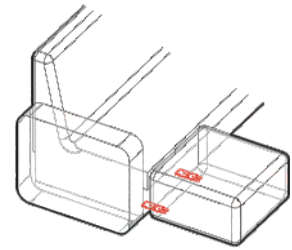
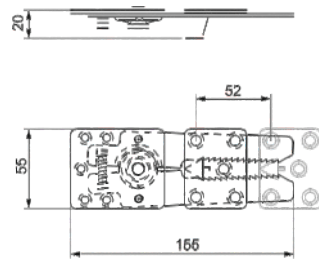

TZ 007-5 MIN 200
 tworzywo plastic

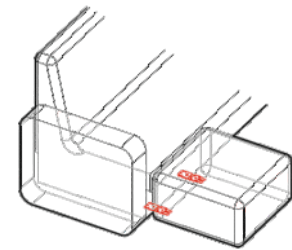
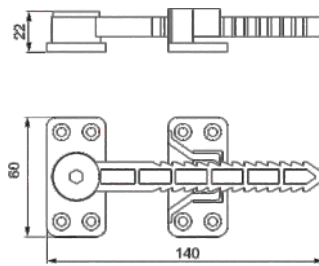
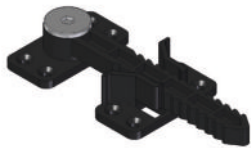

CZ 034-1 MIN 100

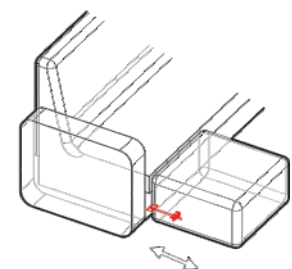
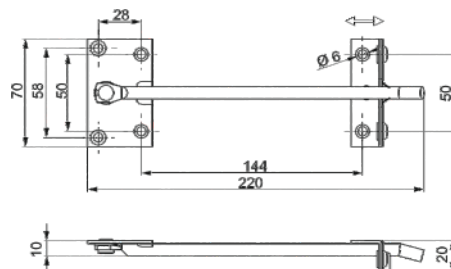

AP 046-1 L=300 MIN 200

AP 041-1 L=230 MIN 200

L - również na życzenie

L - available also on request

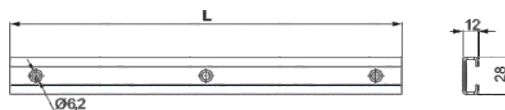

AR 006-D-1 Lewy Left MIN 250

AR 006-C-1 Prawy Right MIN 250

Do wysuwu siedzisk To extend the seat

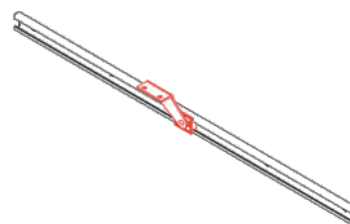
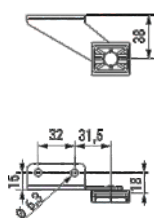

AS 052-J-5 L=650 MIN 100

L - również na życzenie

L - available also on request

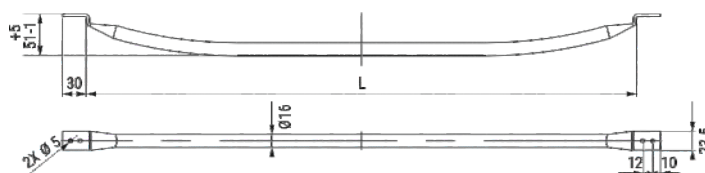

AKCESORIA Z TWORZYW SZTUCZNYCH :: PLASTIC ACCESSORIES

- **TO 001-4** L=380 H=70 F=50 MIN 200
- **TO 002-4** L=510 H=70 F=50 MIN 200
- **TO 003-4** L=790 H=80 F=60 MIN 125

tworzywo
plastic

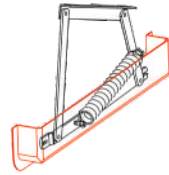
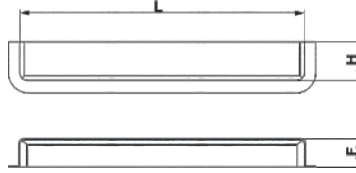
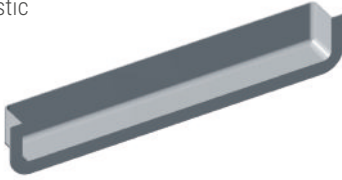

- **TS 011-5** MIN 1000

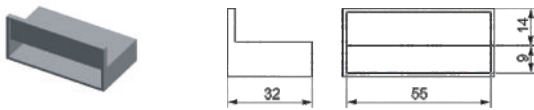

- **TS 078-4** MIN 2500

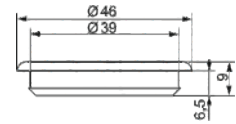

- TS 184-5** MIN 1000

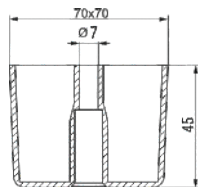

- TS 026-A-5** H1= 65 H2=15 MIN 1000

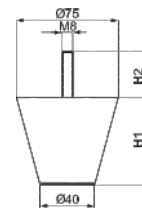

- TS 023-5** H=25 MIN 1000
- TS 024-5** H=35 MIN 1000
- **TS 038-5** H=50 MIN 400

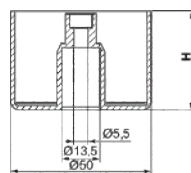

- TS 046-B-5** H1=50 H2=25 MIN 1000

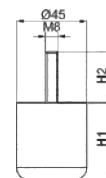

TS 113-5
MIN 1000

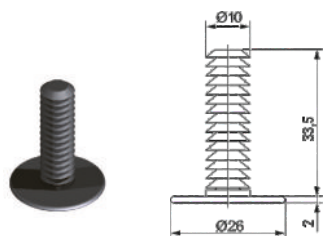

TS 186-13 Elastomer MIN 1000



TS 009-5
MIN 2000

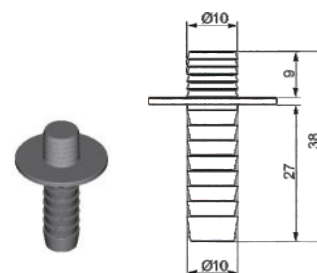

TS 016-5 MIN 1000



TS 018-5
MIN 1500

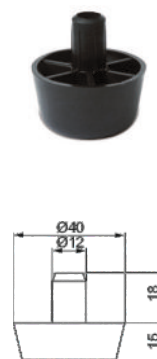

TS 272-5
MIN 1000

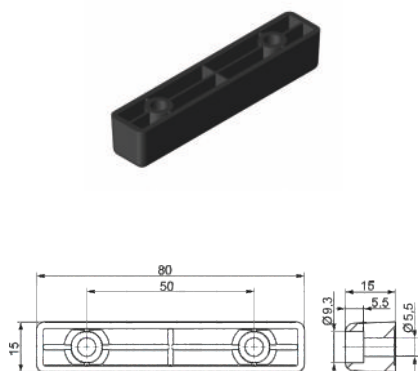

TS 230-5 A=28 B=16 MIN 1000

TS 231-5 A=38 B=24 MIN 1000

TS 232-5 A=58 B=48 MIN 1000

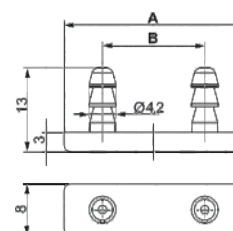

TS 042-5 MIN 1000

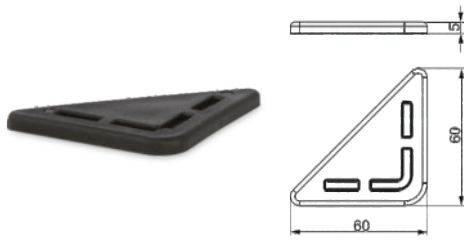

TS 033-5 H=15 MIN 1000
TS 270-5 H=25 MIN 1000

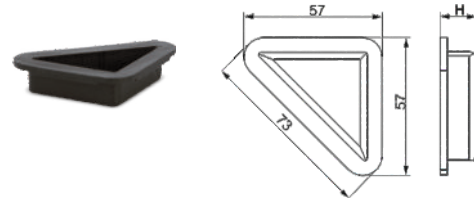

TS 150-5 MIN 1000

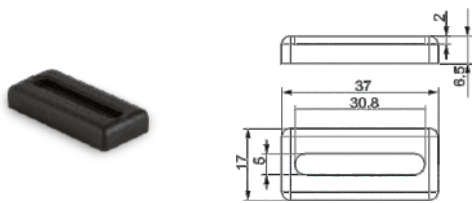

TS 180-5 MIN 1000

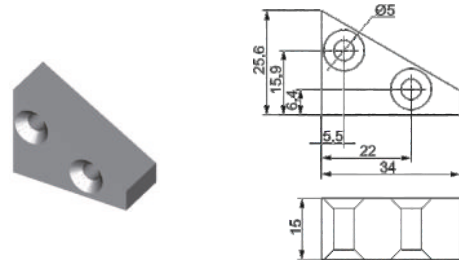

TS 083-4 MIN 1000

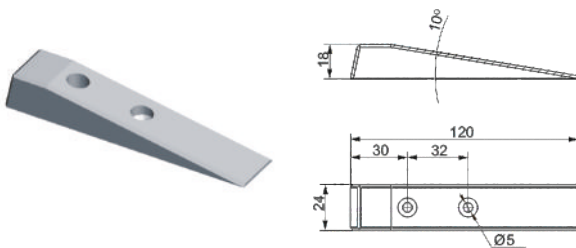

TS 080-4 MIN 1000

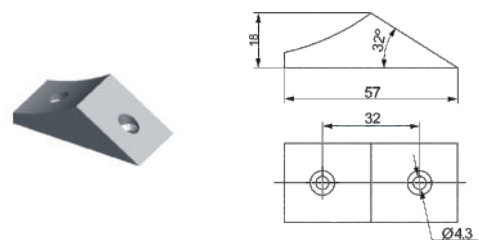

NOGI MEBLOWE FURNITURE LEGS

HYMEN

NG 273 H150 L880  5,60 MIN 40

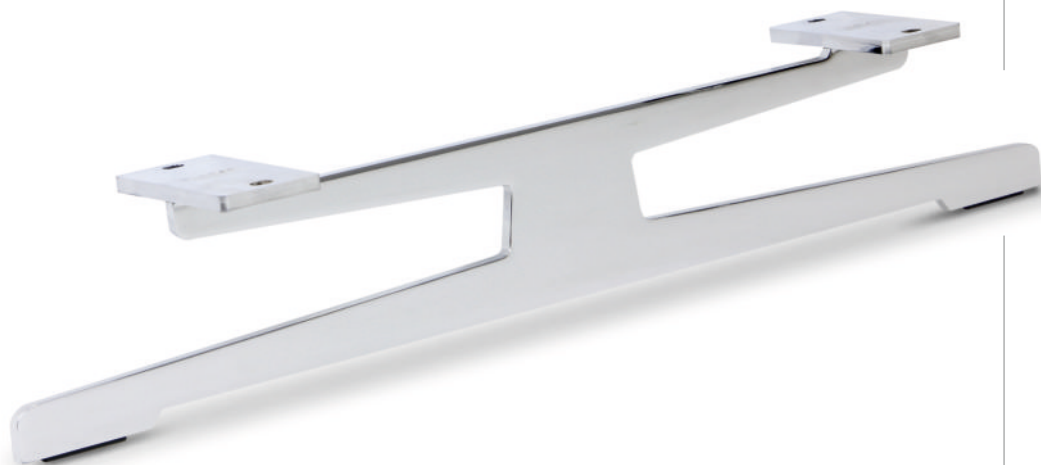

LYNX

NG 272 H200 L900  6,40 MIN 40

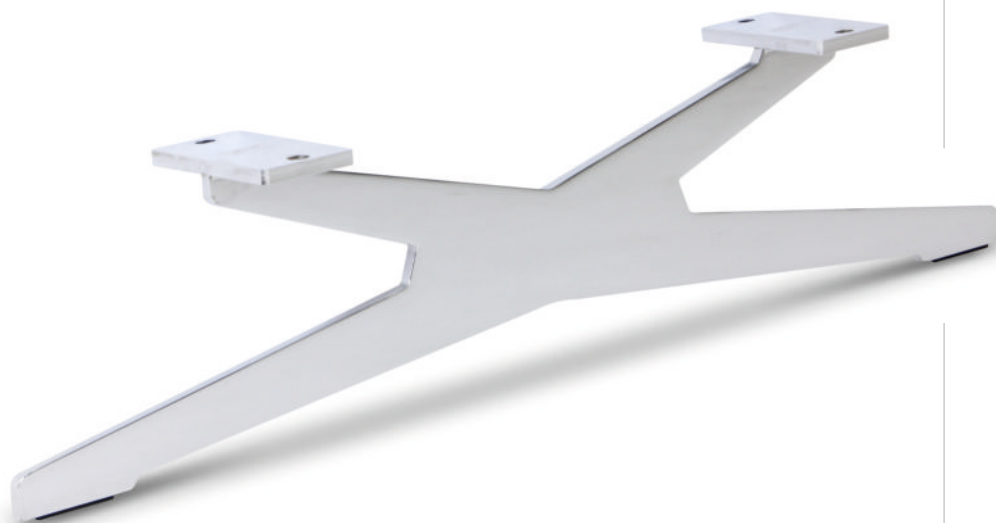

PROXI**NG 134** H150 MIN 100**CORAL**

BG 551-C	H100	MIN 100
BG 551-B	H120	MIN 100
BG 551	H153	MIN 100

ROSA**BG 149** H130 MIN 100

INDUSTRIAL PROPERTY

FENIKS ALU**BA 017** H160 MIN 96

INDUSTRIAL PROPERTY

**TUKAN ALU****BA 016** H180 MIN 96**PASO ALU****BA 006** H150 MIN 96

PODSTAWY MEBLOWE FURNITURE BASES

GARDA

SP 151 H38 Ø700 MIN 50

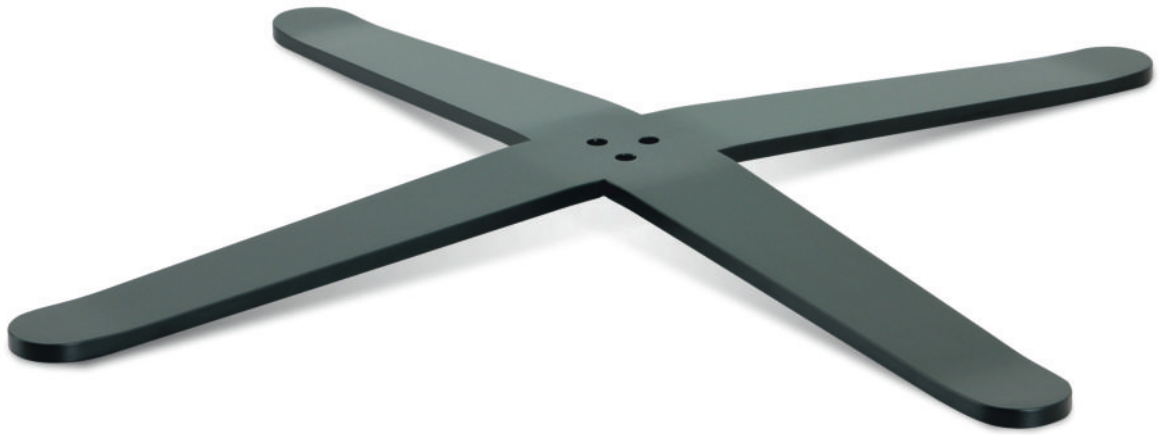

GARDA V

SP 231 H68 Ø730 MIN 50



KOMO**SP 788-C** H70 Ø700 MIN 40**KOMO V****SP 233** H58 Ø730 MIN 50

RIO V**SP 232** H70 Ø730 MIN 50**DISH****SP 085** Ø580 MIN 50

wykończenia ozdobne -28, -27, -19 str. 1

decorative finishings -28, -27, -19 p. 1



MECHANIZMY OBROTOWE SWIVEL MACHANISMS

SP 410-C H275 MIN 50
H - na życzenie/at request

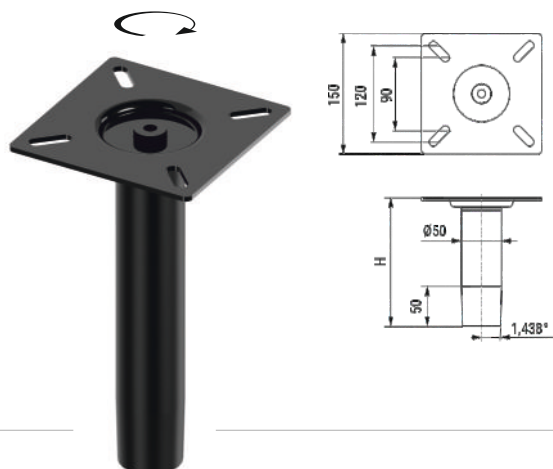

SP 400-A H300 MIN 50
H - na życzenie/at request

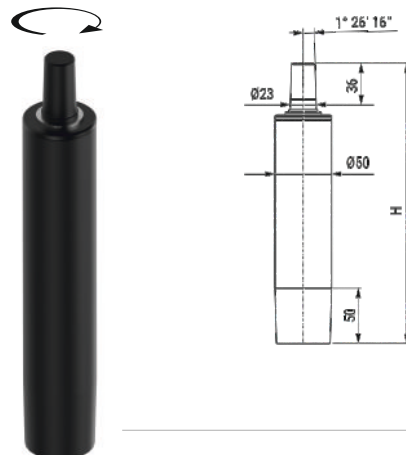

SP 420-C H275 MIN 50
H - na życzenie/at request

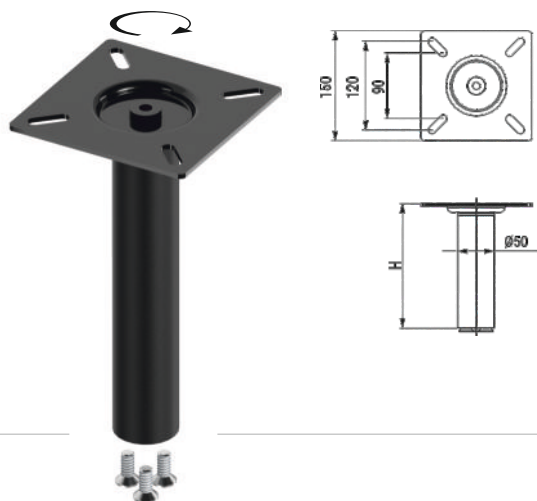

SP 430-A H260 MIN 50
H - na życzenie/at request

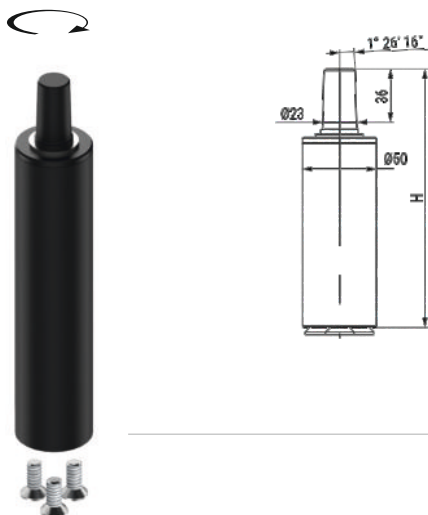

SP 070-B-5 MIN 50

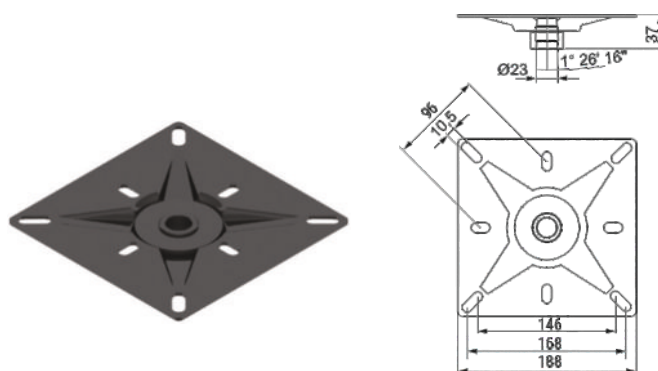

MECHANIZM OBROTOWY Z AUTOMATYCZNYM POWROTEM
SWIVEL MECHANISM WITH AUTO-RETURN

SP 405 H280 MIN 40

H - na życzenie/at request

współpracuje ze wspornikiem SP 070-B-5
cooperates with support SP 070-B-5

360° Auto-return

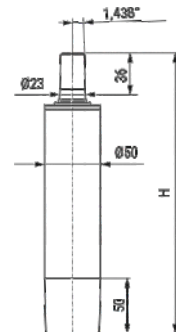

MECHANIZM OBROTOWY Z AUTOMATYCZNYM POWROTEM
SWIVEL MECHANISM WITH AUTO-RETURN

● SP 960-A-5 MIN 10

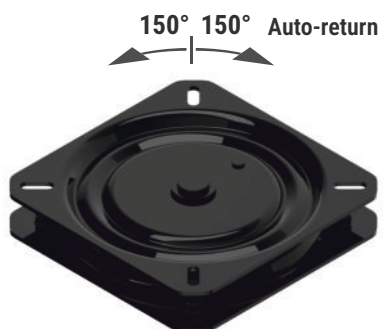
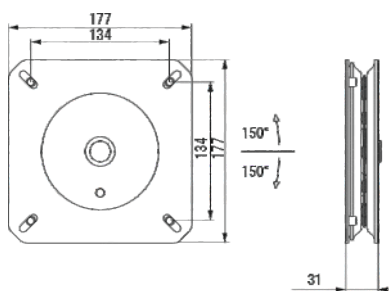

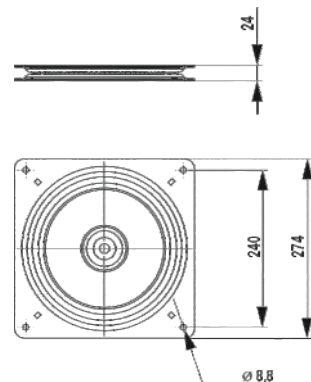
CONEY**SP 234-A-12** MIN 40z mechanizmem obrotowym
with swivel mechanism**CENTRO****SP 969-C-5** Ø550 MIN 50**SP 969-A-5** Ø580 MIN 50**SP 969-5** Ø610 MIN 50**SP 969-B-5** Ø860 MIN 50● **SP 968-5** MIN 10

INDEX

A

AH 001-1 55
AH 025-1 55
AH 050-1 56
AH 055-4 56
AK 003-1 57
AK 006-1 57
AK 012-1 57
AK 034-1 57
AK 087-1 30, 58
AK 131-1 30, 58
AK 133-1 44
AK 442-1 32
AK 640-5 14
AL 011-1 54
AL 034-1 54
AL 051-5 18, 20
AL 094-1 44
AL 200-1 54
AP 041-1 32, 64
AP 046-1 32, 64
AR 006-A-1 32
AR 006-C-1 64
AR 006-D-1 64
AR 101-1 60
AR 104-1 60
AR 105-1 60
AR 108-1 59
AR 109-1 59
AR 110-1 59
AR 115-1 61
AR 116-1 61
AR 165-1 59
AR 167-1 61
AR 168-1 61
AR 168-A-1 16
AR 172-1 59
AR 174-1 59
AR 189-1 59
AR 190-1 60
AR 205-1 60
AR 228-1 14
AR 253-5 14, 16
AS 052-J-5 64
AS 105-1 26
AS 106-1 6
AS 108-1 27
AS 109-1 27
AS 119-1 4, 6, 8, 22, 25, 52

AS 126-1 27
AS 129-1 27
AS 130-1 25, 26
AS 135-1 4, 6, 8, 22
AS 138-1 28
AS 189-1 6
AS 252-1 4, 6, 8, 22
AS 438-1 10, 12
AS 477-1 26
AS 552-1 24
AS 624-1 10, 12
AS 637-1 10, 12
AZ 321-1 20, 62
AZ 326-1 62
AZ 357-1 62
AZ 359-1 62

B

BA 006 70
BA 016 70
BA 017 70
BG 149 69
BG 551 69
BG 551-B 69
BG 551-C 69

C

CB 029-5-3G 22
CB 033-5-3G 22, 31
CH 009-1 55
CH 031-1 22, 56
CK 017-5 30, 58
CK 028-5 30, 58
CZ 034-1 63
CZ 149-B-1 63
CZ 149-C-1 63
CZ 181-1 22, 56

K

KDH026 14, 16, 32, 35, 36, 49, 50
KDH057 16, 32, 35, 36, 49, 50
KDH107D 14, 16, 32, 35, 36, 49, 50
KDPT007N-246-X 36
KDPT007-XA 14
KDPT007-XSA 16
KDYJT013-A-X 32
KDYJT013-B-X 35
KO 012-5 23
KO 013-B-5 23
KO 128-1 23

L

LZ 037-5 20, 61

M

MK 083-8 53

N

NG 134 69
NG 272 68
NG 273 68
NG 319-5 10
NG 320-5 8

P

PB 031-5 33
PB 033-1 39
PB 033-I-1 39
PB 041-B-5 34
PC 024-1 24
PC 025-1 24
PC 026-1 41
PC 090-I-5 51
PC 136-A-1 40
PC 136-F-1 40
PC 146-5 49
PC 150 50
PD 006-1 24

PD 122-1 28
PD 126-B-1 28
PF 001-B-5 19
PF 003-5 19
PF 016-5 3G 22
PF 022-5 22
PF 085-5 21
PF 107-B-5 4
PF 190-Z-5 6
PF 191-5 8
PF 202-AM-5 10, 12
PF 277-5 10
PF 278-5 12
PF 280-H-5 6, 12
PF 280-J-5 6, 12
PF 290-A-5 4, 6, 16
PF 290-W-5 8
PF 300-5 14
PF 301-A-5 16
PL 001-4 25
PL 134-4 25
PM 142-4 26
PM 147-4 26
PP 150-1 43
PP 241-1 45
PP 270-1 37
PP 343-J-1 46
PP 510-8 47
PP 555-N-1 42
PP 812-1 38
PT 009-5 52
PT 009-C-5 52
PT 011-P-5 51
PZ 180-4 27
PZ 182-4 27
PZ 217-A-5 30
PZ 245-5 31

R

RU 820-5 29
RU 820-A-5 29
RU 820-B-5 29
RU 821-5 29
RU 821-A-5 29
RU 821-B-5 29

INDEX

S

SF 121-5	35
SF 122-5	36
SF 124-5	36
SP 070-B-5	74
SP 085	73
SP 151	71
SP 231	71
SP 232	73
SP 233	72
SP 234-A-12	77
SP 400-A	74
SP 405	75
SP 410-C	74
SP 420-C	74
SP 430-A	74
SP 788-C	72
SP 960-A-5	76
SP 968-5	77
SP 969-5	77
SP 969-A-5	77
SP 969-B-5	77
SP 969-C-5	77
SZ 317-A	48
SZ 318	48
SZ 509-E-8	48

T

TO 001-4	25, 65
TO 002-4	26, 65
TO 003-4	27, 65
TS 009-5	66
TS 011-5	65
TS 016-5	66
TS 018-5	66
TS 023-5	65
TS 024-5	65
TS 026-A-5	65
TS 033-5	67
TS 038-5	65
TS 042-5	67
TS 046-B-5	65
TS 078-4	65
TS 080-4	67
TS 083-4	67
TS 113-5	66
TS 150-5	67
TS 168-8	47
TS 169-8	47
TS 180-5	67
TS 184-5	65
TS 186-13	66
TS 230-5	66
TS 231-5	66
TS 232-5	66
TS 270-5	67
TS 272-5	66
TZ 007-5	63

W

WS 189-5	18
WS 578-5	18
WU 429-D-5	20
WU 437-Z-5	20
WU 573-5	18, 20

X

XRA 0045-A	27
XRA 0046-A	30
XRA 0064-A	30
XRA 0069-A	25, 26
XRA 0083-A	27, 28
XRA 0115	51
XRA 0118-A	30
XRA 0128	31
XRA 0129	31
XRA 0160-A	25, 26
XRA 0168-A	27
XRA 0213	51



STALMOT

STALMOT & WOLMET sp. z o.o.

Siedziba Spółki / Headquarters
13-100 Nidzica, ul. Sienkiewicza 2
Poland
EU VAT: PL 739 385 9124

www.stalmot.com

Dział Handlowy/ Sales Department Nidzica
tel: +48 506 564 392

Dział Handlowy/ Sales Department Wolsztyn
tel: +48 604 218 387



Niniejszy katalog nie jest ofertą w rozumieniu przepisów Kodeksu Cywilnego. Producent zastrzega sobie prawo do dokonywania zmian konstrukcyjnych w wyrobach, nie zmieniając ich ogólnego charakteru. Zdjęcia produktów i ich kolorystyka umieszczone w katalogu handlowym mogą się różnić od faktycznego wyglądu. Wszelkie prawa zastrzeżone.

This catalogue does not constitute an offer within the meaning of the Polish Civil Code. The company reserves the right to design changes to products, without changing their general character. Photos and colours of the products shown in this catalogue may slightly vary from the actual product. All Rights Reserved.